

The JEWELRY *Box*™



OWNERS AND SERVICE MANUAL INNOVATIVE CONCEPTS IN ENTERTAINMENT INC.

10123 MAIN STREET, CLARENCE, NY 14031

SERVICE: 1-716-759-0360

FAX: 1-716-759-0884

E-MAIL: service@icegame.com

WEBSITE: www.icegame.com

TABLE OF CONTENTS

INTRODUCTION.....	PAGE 3
• GAME FEATURES	
• GAME PLAY	
SET-UP / TESTING / MAINTENANCE.....	PAGE 4 –12
• SAFETY PRECAUTIONS	
• GAME SET-UP	
• ASSEMBLY	
• TESTING	
• CLEANING	
PROGRAMMING.....	See Insert
QUICK TROUBLESHOOTING.....	PAGE 13 –15
• PROBLEMS AND SOLUTIONS	
GAME REPAIR.....	PAGE 16 –18
• GLASS REPLACEMENT	
• MECHANICAL REPAIR	
• ELECTRICAL / ELECTRONIC REPAIR	
CRANE ASSEMBLY DIAGRAMS.....	PAGE 19 –22
SCHEMATICS / WIRING DIAGRAMS.....	PAGE 23 –40
WARRANTY INFORMATION.....	PAGE 48

INTRODUCTION

GAME FEATURES

Thank you for your purchase of the new **JEWELRY CRANE™** game from I.C.E.

The brand new **JEWELRY CRANE™** all metal crane game by I.C.E. was designed with the operator in mind. Reliability, low maintenance, themed cabinetry and all metal construction are the key design features, exactly what is needed to ensure a combination of long life and high profit.

With nearly the entire construction made of metal, it was only natural to Powder Epoxy Coat everything, inside and out. This provides the owner-operator with a game that will certainly outlast its wooden counterparts for many years to come. The major advantages of all metal construction include:

- Vault like security
- Long service life
- Low maintenance
- High durability

All windows of the **JEWELRY CRANE™**, are 1/4" tempered plate glass to provide an easy to clean, maximum safety, scratch resistant surface. Other features include: 41 strand conductor cables (to prevent fatigue), a full range of operator adjustable software and a newly designed crane mechanism.

The first step in I.C.E.'s new crane design was to select several leading cranes available on the market today, observe and determine what problems can be or are causes of failure and costly down time. I.C.E. then surveyed operators nation wide, requesting information like:

- What are the leading causes of crane failures in your locations
- What are some problems in servicing cranes
- What changes would you make to current cranes to create a better machine

I.C.E.'s engineers then compiled all critical data, addressed and corrected each problem and used this information to create what we now call the **JEWELRY CRANE™**.

This method of design ensures that the needs of the owner-operators dictate the final design parameters, for who knows a cranes attributes and faults better than a crane operator.

GAME PLAY

As coins are inserted into the **JEWELRY CRANE™** all metal game, a "Ding" is heard for each coin inserted. When sufficient coins have been inserted, the claws click closed and then reopen, which signals the start of the game. The crane will then position itself in the middle of the "play field*" and remain there, until the player is ready.

When the player has moved the joystick or pressed the buttons to move the crane, the timer on the right display will begin to count down. The player will then position the crane above the prize they are attempting to win and press the drop button to lower the claw.

If the nudging option is on, then the player will have the ability to keep "nudging" the claw each time the button is pressed to home in on the chosen prize. If the nudging option is off, then the player will have only one chance to drop the claw.

When the claw has fully dropped, it will close and retract to its uppermost position. The crane will then automatically position itself over the prize chute at the rear of the cabinet. The claw will then open, releasing the prize into the prize chamber. The player can now remove the prize from the chamber through the prize door located in the front, lower left corner of the game. The game is now at its home position and is ready for the next player in line.

SETUP / TESTING / MAINTENANCE

BEFORE YOU BEGIN

IMPORTANT: FAILURE TO FOLLOW THESE DIRECTIONS CLOSELY COULD CAUSE SERIOUS DAMAGE TO YOU AND/OR YOUR GAME.

WARNING: WHEN INSTALLING THIS GAME, A 3 PRONG GROUNDED A.C. RECEPTACLE MUST BE USED. FAILURE TO DO SO COULD RESULT IN INJURY TO YOURSELF OR OTHERS. FAILURE TO USE A GROUNDED RECEPTACLE COULD ALSO CAUSE IMPROPER GAME OPERATION, AND / OR DAMAGE TO THE ELECTRONICS

DO NOT DEFEAT OR REMOVE THE GROUNDING PRONG ON THE POWER CORD FOR THE SAME REASON AS GIVEN ABOVE. USING AN IMPROPERLY GROUNDED GAME COULD VOID YOUR WARRANTY.

HAVE A QUALIFIED ELECTRICIAN CHECK YOUR A.C. RECEPTACLE TO BE SURE THE GROUND IS FUNCTIONING PROPERLY.

GAME SET-UP

BEFORE PLUGGING THE GAME IN OR TURNING IT ON, BE SURE THE GAME HAS BEEN SET TO THE PROPER VOLTAGE.

ASSEMBLY INSTRUCTIONS

1. Carefully unbox the game from its packaging.
2. Using the supplied keys, unlock the front door of cabinet.
3. Cut all tie wraps holding the wagon assembly and crane assembly in place.
4. Plug the game into a three prong grounded receptacle. **NOTE:** The appliance must be positioned such that the plug is accessible during use.
5. The game is now ready for start up.

TESTING

After the initial setup, it is time to test your game for proper operation.

1. Locate the game in its permanent location and lock the casters.
2. Be sure that the game has been properly plugged into a three prong grounded outlet and that the receptacle is in good working order.
3. If using an extension cord, be sure it is a three prong grounded type of at least 16 Ga.
4. Verify that the game is set up for the proper voltage and turn the power to the game on.
5. The game will run through a test mode at every start up. See test mode explanation in the programming section for details.
6. Insert coins/bills at least ten times into the coin mech/bill acceptor to assure proper operation.
7. Check the credit and prize counters for proper operation.
8. Check that the door disconnect switch works properly.
9. Check game volume during busy time at location to set it at the proper level.

CLEANING

Regular cleaning of the game will keep it looking new and greatly enhance its appeal.

Clean the windows of your **JEWELRY CRANE™** with a standard window cleaner such as Windex®

Clean the cabinet sides with a good cleaner such as "Fantastik" or "409" and a soft rag. A mild soapy solution can also be used.

NOTE: DO NOT USE ALCOHOL, THINNERS OF ANY KIND OR PINBALL PLAYFIELD CLEANERS ON ANY OF THE CABINET SURFACES, ESPECIALLY THE DECALS.

IF YOU HAVE ANY QUESTIONS OR COMMENTS REGARDING INSTALLATION OR PROPER FUNCTION OF YOUR GAME, PLEASE CALL OUR SERVICE DEPARTMENT AT 1-716-759-0360

SETUP / TESTING / MAINTENANCE

MANUAL SETTING

Initial adjustment tips

- It is important to know that a mechanical adjustment is considered a “Macro adjustment” or a large adjustment, and that a software adjustment is considered a “Micro adjustment” or a fine adjustment.
- NOTE: These adjustments need only be performed when setting up the crane for the first time or when major changes to plush size and/or shape occur. Once a configuration is determined for your particular requirements, the same configuration in another CRANE GAME may require only minor adjustments.
- It is advisable that you position your plush such that the “Eyes” are facing forward and looking at your potential customers.
- To maintain proper payout in either Manual mode or Skill leveling mode, ALL plush in the crane should be of similar size, shape and weight. DO NOT attempt to use 6” plush with 14” plush in the same crane as you are likely to have very different payout % from week to week which requires constant monitoring and adjusting.
- Set option 0 (Game mode) for game type you desire.
- Set option 3 (Game cost) for you particular game.
- For the following tests, make sure that option 9 (Skill leveling strength) is set to 00. Any setting other than 00 and Skill leveling is enabled and incorrect results may occur.
- Make sure that the claw tips, when closed, are just touching. DO NOT allow them to overlap, for the claw could mechanically bind, causing down time.
- CHECK IF YOU HAVE THE CORRECT CLAW SHAPE. Assuming you have a medium claw, standard on most cranes, set option 8 to 40, 9 to 00 and play the game approximately 25 times. At this level, you should have difficulty picking up plush.
 - If you are able to pick up plush rather easy, you have the wrong claw shape or size and should go to the end of this section and see CLAW SHAPE.
 - If you are unable to pick up plush, then set option 8 to 99 and play 25 games. You should now be able to pick up plush fairly consistently. If this is true, continue on to the next step. NOTE: When the game is first packed, it is often difficult to pick up plush until an area is cleared to maneuver in. Take this in to account while determining if the claw size or shape is correct.
- Initially set option 8 (Manual strength) based on your plush size, such that the claw is just able to hold the plush when closed. If you are unsure, a good starting point for option 8 is 60 for average size plush and our standard medium claw. NOTE: When in programming mode at option 8, the claw will begin the open and close at approximately 5 second intervals. The operator can then associate the claw strength number on the right display with an actual “physical” claw strength at the claw.
- Knowing the cost of a game, the average cost of a piece of plush and the desired payout %, calculate the proper plush dispensing intervals for your setup, using the following formula:

SETUP / TESTING / MAINTENANCE

Calculation Option 1

- 1) $100 * (\text{Game cost}) = A$ (# of dollars received for 100 games)
- 2) $A * (\text{Desired payout \%}) = B$ (# of dollars worth of plush that should be dispensed in 100 games)
- 3) $B / (\text{Cost of plush}) = C$ (# of pieces of plush that should be dispensed in 100 games)
- 4) $100 / C = Y$ (Proper plush dispensing intervals)

OR

Calculation Option 2

- 1) $(\text{Plush Cost}) / (\text{Game Cost}) = X$ (# of games required to pay for one piece of plush)
- 2) $(X) / (\text{Desired Payout \%}) = Y$ (Proper plush dispensing interval)

EXAMPLE

Game cost	= \$0.50
Avg. cost of 1 plush	= \$2.00
Desired payout %	= 33%

Example Calculation Option 1

- 1) $100 * (\$0.50) = \50
- 2) $\$50 * (.33) = \16.5 worth of plush in 100 games to give a 33% payout
- 3) $\$16.5 / (\$2.00) = 8.25$ pieces of plush per 100 games to give a 33% payout
- 4) $100 / (8.25) = 12.12$ round off to 12.

OR

Example Calculation Option 2

- 1) $\$2.00 / (\$0.50) = 4$
- 2) $(4) / (.33) = 12.12$ round off to 12

NOTE: This means that for approximately every 12th game played, 1 piece of plush should be won.

SETUP / TESTING / MAINTENANCE

Armed with the information particular to your game (Proper plush dispensing intervals determined above) play at least 50 games and see if the correct number of plush have been dispensed. (For the example above, in 50 games you should have dispensed approximately 4 pieces of plush. (Every 12.12 games) NOTE: The more games you play during the "TEST", the more accurate your accounting will be). When 50 games have been played, calculate the payout % using the formula below:

$$1) \frac{(\# \text{ of plush dispensed}) * (\text{Cost of 1 pc. of plush})}{(\# \text{ of games played}) * (\text{Cost of game})} = \text{Payout \%}$$

EXAMPLE

Cost of a game	= \$0.50
Cost of 1 pc. of plush	= \$2.00
# of plush dispensed	= 55
# of games played	= 423

$$\frac{(55) * (\$2.00)}{(423 * (\$0.50))} = 52 = 52\% \text{ payout}$$

If the calculated payout is very high, your desired payout + 10% or more, it will be necessary to make a macro adjustment or move the claw tips apart slightly by loosening the three screws holding the claw slider to the coil housing and moving the claw slider up slightly. (See Fig. 1) NOTE: MOVING THE CLAW SLIDER 1/8th OF AN INCH COULD CHANGE YOUR PAYOUT BY AS MUCH AS 40%. BE SURE TO MOVE THE SLIDER IN VERY SMALL INCREMENTS SO AS NOT TO OVERSHOOT YOUR DESIRED PAYOUT.

If the calculated payout is slightly high, your desired payout + less than 10%, then you can make a micro adjustment or software claw strength adjustment at Option 8.

Conversely, if the calculated payout is very low or slightly low, you will need to make a macro or micro adjustment accordingly.

Repeat the 50 games test and calculate the Payout %. Repeat the mechanical adjustment until you are within 10% of your desired payout. You can now enter the programming mode and adjust Option 8 (Mechanical strength) up or down slightly to achieve your desired payout. Your game is now set up according to your Desired Payout, Game Cost and Plush Cost.

If after using the initial adjustment tips above, you are still having difficulty in setting up your game, please call the I.C.E. service line at 1-716-759-0360.

SETUP / TESTING / MAINTENANCE

SKILL LEVELING SETTINGS

Initial adjustment tips

- Before setting up Skill leveling, it is highly advisable to set up manual percentaging. This is a precaution in the unlikely event that the prize sensor fails or error code 10 or 11 is logged. If either one of these situations occurs, the game will AUTOMATICALLY revert to manual percentaging settings, allowing the game to still function until the error is corrected. If your manual settings are not set up, it may be possible to dispense too much plush resulting in a loss of revenue for that week, or dispensing too little plush, causing your customers to feel as though they can not win, which will eventually result in a loss of play and revenue.
- It is important to know that a mechanical adjustment is considered a “Macro adjustment” or a large adjustment, and that a software adjustment is considered a “Micro adjustment” or a fine adjustment.
- **SPECIAL NOTE:** When using Skill leveling, you will be required to reset the computer memory once a week. This is done to clear computer memory of “portions” of plush that were to be dispensed and have not been OR “portions of plush that have not been dispensed and should not have been. Since we are human, we think of plush as whole entities. The computer has the ability to track plush as pieces or fractions of pieces. For example: If we want a 34% payout based on \$2.00 average cost plush and \$0.50 game play, we want APPROXIMATELY 1 piece of plush dispensed every 12 games. The actual number is 1 piece of plush for every 11.7647 games. The computer from week to week may have a bunch of the little pieces of plush that it did not give away and will eventually add up and hit the limit of 8 pieces not dispensed and take you out of Skill leveling Mode. Often this confuses an operator since the game worked very well for several weeks or even longer, but then kicked into Manual Mode and gave them an Error 11. To prevent this, it is HIGHLY suggested you reset the computer once a week using the following procedure:

Once a week, or after a minimum of 500 games, enter the programming mode and change the % payout number up by one number and exit programming mode. The following week, enter the programming mode and change the % payout number down by one number. Example: Week one, the % payout number = 33. Week two, change % payout to 34. Week three, change % payout number back to 33, etc. Using % payout will have the smallest change on payout yet it will reset memory and keep things working as intended.

- NOTE: These adjustments need only be performed when setting up the crane for the first time or when major changes to plush size and / or shape occur. Once a configuration is determined for your particular requirements, the same configuration in another CRANE GAME may require only minor adjustments.
- It is advisable that you position your plush such that all “Eyes” are facing forward and looking at your potential customers.
- To maintain proper payout in either Manual Mode or Skill leveling Mode, ALL plush in the crane should be of similar size, shape and weight. DO NOT attempt to use 6” plush with 14” plush in the same crane as you are likely to have very different payout % from week to week which requires constant monitoring and adjusting.
- Set Option 0 (Game mode) for game type you desire
- Set Option 3 (Game cost) for your particular game.
- Make sure that the claw tips, when closed, are just touching.
- To check if you have the correct claw shape, set Option 8 to 50, Option 9 to 00 and play the game approximately 25 times. At this level, you should have difficulty picking up plush.

SETUP / TESTING / MAINTENANCE

- If you are able to pick up plush, you have the wrong claw shape or size and should go to the end of this section and see CLAW SHAPE
- If you are unable to pick up plush, then set Option 8 to 99 and play 25 games. You should now be able to pick up plush fairly consistently. If this is true, continue on to the next step. NOTE: When the game is first packed, it is often difficult to pick up plush until an area is cleared to maneuver in. Take this into account while determining if the claw size or shape is correct.
- Make sure Option 8 (Manual strength) is set up as detailed above before setting up Skill leveling.
- Determine the proper Minimum Claw Strength by setting Option to 9 initially to 60 on the right display. Notice that the claw is opening and closing on a 5 second interval. Hold an average size piece of plush in the claw as it closes and note whether it has enough claw strength to hold the plush. Repeat this procedure until you find the breaking point where the claw will hold the piece of plush but if you lower the strength of the claw by 1 or 2 points, the claw will no longer be able to hold the plush. This will be the number you want to use as your Skill leveling strength (Option 9). It will allow a skilled player to move plush around and have the ability to win at any time, yet requires a skilled player to win easily.
- Set Option 16 (Plush cost) based on the cost of your plush.
- Set Option 17 (Desired payout %) based on your desired payout.
- Knowing the cost of a game, cost a piece of plush and the desired payout %, calculate the proper plush dispensing intervals using the following formula:

Calculation Option 1

- 1) $100 * (\text{Game cost}) = A$ (# of dollars received for 100 games)
- 2) $A * (\text{Desire payout \%}) = B$ (# of dollars worth of plush that should have been dispensed in 100 games)
- 3) $B / (\text{Cost of plush}) = C$ (# of pieces of plush that should be dispensed in 100 games)
- 4) $100 / C = Y$ (Proper plush dispensing intervals)

OR

Calculation Option 2

- 1) $(\text{Plush Cost}) / (\text{Game cost}) = X$ (# of games required to pay for one piece of plush)
- 2) $(X) / (\text{Desired payout \%}) = Y$ (Proper plush dispensing interval)

EXAMPLE

Game cost	= \$0.50
Avg. cost of 1 plush	= \$2.00
Desired payout %	= 33%

Example Calculation Option 1

- 1) $100 * (\$0.50) = \50
- 2) $\$50 * (.33) = \16.5 worth of plush in 100 games to give a 33% payout
- 3) $\$16.5 / (\$2.00) = 8.25$ pieces of plush per 100 games to give a 33% payout
- 4) $100 / (8.25) = 12.12$ round off to 12

OR

SETUP / TESTING / MAINTENANCE

Example Calculation Option 2

$$1) \$2.00 / (\$0.50) = 4$$

$$2) (4) / (.33) = 12.12 \text{ round off to } 12$$

NOTE: This means that for approximately every 12th game played, 1 piece of plush should be won.

Armed with the information particular to your game (Proper plush dispensing interval determined above) play at least 50 games and see if the correct number of plush have been dispensed. (For the example above, in 50 games you should have dispensed approximately 4 pieces of plush. (Every 12.12 games) **NOTE:** The more games you play during the "TEST", the more accurate your accounting will be). When 50 games have been played, calculate the payout % using the formula below:

$$1) \frac{(\# \text{ of plush dispensed}) * (\text{Cost of 1 pc. Of plush})}{(\# \text{ of games played}) * (\text{Cost of game})} = \text{Payout \%}$$

EXAMPLE

Cost of a game	= \$0.50
Cost of 1 pc. Of plush	= \$2.00
# of plush dispensed	= 55
# of games played	= 423

$$\frac{(56) * (\$2.00)}{(423 * (\$0.50))} = 52 = 52\% \text{ payout}$$

If the calculated payout is very high, your desired payout + 10% or more, it will be necessary to make a macro adjustment or move the claw tips apart lightly by loosening the three screws holding the claw slider to the coil housing and moving the claw slider up slightly. (See Fig. 1) **NOTE:** MOVING THE CLAW SLIDER 1/8TH OF AN INCH COULD CHANGE YOUR PAYOUT BY AS MUCH AS 40%. BE SURE TO MOVE THE SLIDER IN VERY SMALL INCREMENTS SO AS NOT TO OVERSHOOT YOUR DESIRED PAYOUT.

If the calculated payout is slightly high, your desired payout + less than 10%, then you can make a micro adjustment or software claw strength adjustment at Option 8.

Conversely, if the calculated payout is very low or slightly low, you will need to make a macro or micro adjustment accordingly.

Repeat the 50 games test and calculate the Payout %. Repeat the mechanical adjustment until you are within approximately 5 - 10% of your desired payout. You can now enter the programming mode and adjust Option 9 (Skill leveling strength) up or down slightly to achieve your desired payout. Your game is now set up according to your Desired Payout, Game Cost and Plush Cost. If at a later date you want to change your game cost, desired payout, plush cost, etc., it is **NOT** necessary to re-adjust your game manually. Just adjust the value option you wish to change in the PROGRAMMING SECTION. The game will adjust to your new configuration.

If after using the initial adjustment tips above, you are still having difficulty in setting up your game, please call the I.C.E. service line at 1-716-759-0360.

SETUP / TESTING / MAINTENANCE

CLAW SHAPE

In an attempt to satisfy all variables associated with proper payout, I.C.E. has opted to include directions on how to reshape your medium claw for a lesser and greater mechanical advantage. On the following page are two medium claw shapes which will give very different mechanical advantages and ultimately very different claw strengths.

- When Option 8 is set to 50, and you are still picking up plush, then you will need to reshape your 3 claws to look more like shape "A". (SEE FIG. 2) NOTE: Be sure to align holes in claw with drawn holes on the template. This will assure proper shaping of the claw.
- When Option 8 is set to 99, and you are unable to pick up plush consistently, then you will need to reshape your 3 claws to look more like shape "B". (SEE FIG. 2) NOTE: Be sure to align holes in claw with drawn holes on the template. This will assure proper shaping of the claw.

These are two claw shapes that I.C.E. has proven to work well, although there are many other shapes that may work. You will need to remove the claws from the claw mechanism by following the steps listed below.

- 1) Remove the claw mechanism from the coil housing by loosening the three screws on the coil slider and removing. Be sure not to lose the small spring around the plunger and the black Rynite washer below the spring. These two parts are critical in the proper operation of the crane mechanism. (SEE FIG. 1)
- 2) Loosen and remove the six small Phillips head machine screws and Nylock nuts attaching the three claws to the coil-claw interconnect and coil spider. (SEE FIG.1)
- 3) Reshape the claws according to the CLAW SHAPE Templates "A" or "B".
- 4) Re-assemble in reverse order. Make sure NOT to over tighten the Nylock nuts attaching the claws to the mechanism, as this would cause binding.

Now that you have reshaped your claws for your plush, return to the beginning of Adjustment tips and proceed through each step.

FIG. 1

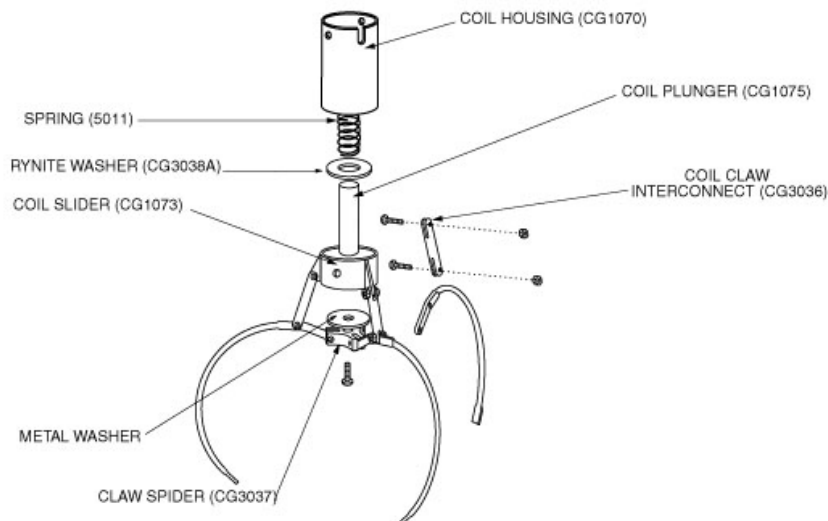

CLAW TEMPLATES

(Fig. 2)

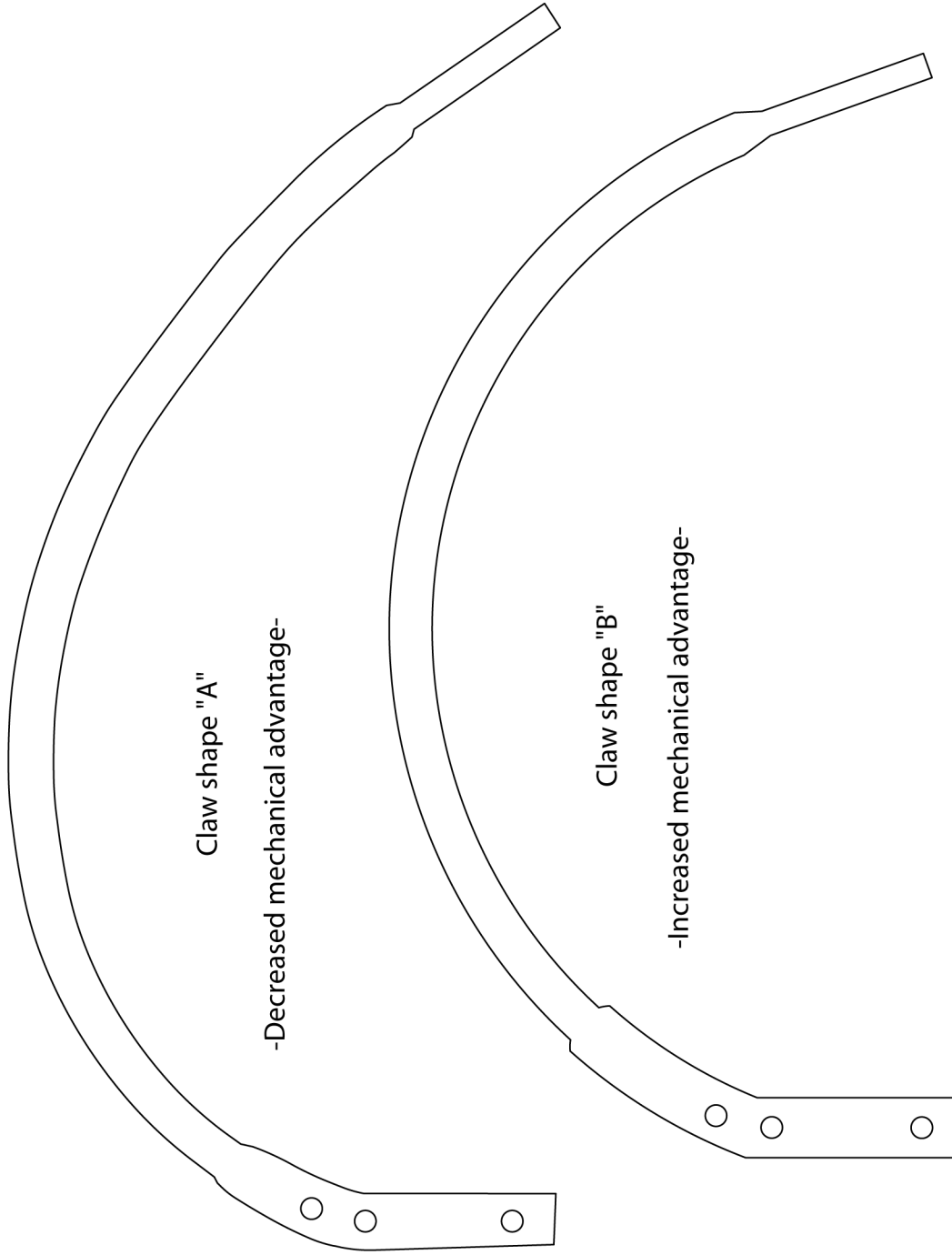

NOTE: These are the two claw shapes that have been thoroughly tested by I.C.E. and are proven to work. They should be used as a guide to increase or decrease the mechanical advantage of the claw for your particular plush. Other claw shapes in-between claw shapes A and B may work but will require further testing.

QUICK TROUBLESHOOTING

PROBLEM	PROBABLE CAUSE	SOLUTION
THE DECIMALS ON THE 4 DISPLAYS ARE LIT UP	THIS IS IN FACT NOT A PROBLEM BUT A WAY OF LETTING THE OPERATOR KNOW THAT THERE WAS A PROBLEM DURING THE START UP MODE	OPEN THE FRONT DOOR AND THE ERROR CODES ARE SHOWN ON THE DISPLAYS. TO ADVANCE THROUGH THE ERROR CODES, PRESS THE FIRE BUTTON
NO GAME POWER	ON-OFF SWITCH ON THE GAME IS TURNED OFF BLOWN A.C. POWER FUSE GAME NOT PLUGGED OR CORD DAMAGED BAD TRANSFORMER TRANSFORMER HARNESS NOT CONNECTED BAD POWER MODULE	TURN POWER ON REPLACE WITH PROPER FUSE CHECK POWER CORD CHECK FOR PROPER VOLTAGES CHECK HARNESS REPLACE POWER MODULE
GAME WILL NOT TAKE MONEY OR GIVE CREDITS CORRECTLY	BAD COIN SWITCH COIN DISCOUNTING SET WRONG COINS PER CREDIT SETTING INCORRECT BAD COIN MECHANISM LOOSE OR DAMAGED HARNESSING BAD MAIN P.C. BOARD	CHECK W/METER AND REPLACE CHECK PROGRAMMABLE SETTING CHECK PROGRAMMABLE SETTING ADJUST OR REPLACE CHECK W/METER—REPAIR REPAIR OR REPLACE MAIN BOARD
DISPLAYS DO NOT WORK	BAD 12V FUSE BAD DISPLAY P.C. BOARD BAD MAIN P.C. BOARD LOOSE OR DAMAGED DISPLAY HARNESSING	REPLACE WITH PROPER FUSE REPAIR OR REPLACE P.C. BOARD REPAIR OR REPLACE P.C. BOARD CHECK W / METER AND REPAIR
CRANE OR WAGON DOES NOT MOVE	BAD MOTOR LOOSE OR DAMAGED HARNESSING BAD SWITCH ON BUTTON OR JOYSTICK BAD HARNESSING TO BUTTONS OR JOYSTICK BLOWN FUSE TO MOTORS ON MAIN P.C.B.	REPLACE MOTOR CHECK W / METER—REPAIR REPLACE SWITCH CHECK W / METER—REPAIR REPLACE WITH PROPER FUSE
CRANE KEEPS TRYING TO MOVE IN TO THE HOME POSITION	BAD LIMIT SWITCH (S) LIMIT SWITCH NOT ALIGNED WITH ACTUATOR	REPLACE SWITCH (S) ALIGN SWITCH AND ACTUATOR
CLAW WILL NOT CLOSE	BLOWN FUSE TO CLAW ON MAIN P.C. BOARD BAD COIL LOOSE OR DAMAGED HARNESSING CLAW HAS MECHANICALLY JAMMED	REPLACE WITH PROPER FUSE REPLACE COIL CHECK W / METER AND REPAIR FIND JAM AND REPAIR
CLAW STAYS CLOSED	BAD DRIVE TRANSISTOR ON MAIN P.C.B. CLAW HAS MECHANICALLY LOCKED	REPLACE TRANSISTOR FIND JAM AND REPAIR
SKILL LEVELING IS NOT FUNCTIONING	PROGRAMMING IS NOT CORRECTLY SET BAD PRIZE SENSOR LOOSE OR DAMAGED SENSOR HARNESS	SET OPTIONS "9", "16" AND "17" REPLACE PRIZE SENSOR CHECK W / METER AND REPAIR
CLAW GOES DOWN AND THEN UP BUT DOES NOT CLOSE	DOWN SWITCH BAD LOOSE OR DAMAGED HARNESS TO DOWN SWITCH	REPLACE DOWN SWITCH CHECK W / METER AND REPLACE
CLAW COMES UP AND ABOUT 10 SEC. PASSES BEFORE CRANE MOVES TO THE HOME POSITION	UP SWITCH BAD LOOSE OR DAMAGED HARNESS TO UP SWITCH BROKEN "UP" SPRINGS	REPLACE UP SWITCH CHECK W / METER AND REPLACE REPLACE SPRINGS
CRANE OR WAGON WHEELS SLIP	MISSING OR DAMAGED O-RING DRIVE BELTS LOOSE SET SCREWS IN WHEELS LOOSE SET SCREWS IN DRIVE COUPLER RAILS NEED TO BE SCUFFED	REPLACE O-RING BELTS TIGHTEN SET SCREWS TIGHTEN SET SCREWS SCUFF TOP OF RAILS WITH SANDPAPER

QUICK TROUBLESHOOTING

- NOTE: A self test will be performed each time the front door is “closed” , the game is powered up, or when you exit programming mode.
- NOTE: The game will not count credits or plush out on either the mechanical or software counters while the front door is open.
- NOTE: If the Wagon does not move smoothly through a full travel from left to right, check to see that the wheel spacing is correct. If the spacing is correct, then check the 2 cabinet rails for burrs that may cause the wheels to bind.
- NOTE: If the Crane does not move smoothly through a full travel from front to back, check to see that the wheel spacing is correct. If the spacing is correct, then check the 2 separator rails for burrs that may cause the wheels to bind.
- NOTE: If the Micro track for the left / right movement is binding during its travel, check to see if the top mirror bracket's edge, also the shelf the micro track rides on, has been de-burred.
- NOTE: If the front door is having trouble closing fully, check to see that all harnessing is out of the way for the door to close. Next, check to see that the prize chamber wall is far enough to the right to allow the right edge of the prize door frame to swing past. Finally, check to see that the door is aligned properly.
- NOTE: If the door will not lock properly or locks with difficulty, check to see that the lock rotates smoothly. Next, check that the lock rods are not binding on the lock cam or the lock rod guides. Next, check that all friction points have been lubricated with molly grease. Finally, if need be, adjust the lock rod guides such that the door closes and locks smoothly.
- NOTE: If the decimals light up on the displays after a self test, an error has been logged. When the door is in the open position, the error codes will be shown on the left display. To advance through the error codes, press the drop button.
- NOTE: If at the beginning of the self test mode, the claw does not drop, one or more of the following may apply. The prize sensor is not working or is blocked. The string or string lever is mechanically binding. The up or down switch is sticking or misaligned from its actuator.
- NOTE: If claw stays closed, it is likely that the diode has blown and the transistor controlling the claw has also blown. Shut off the game immediately and have a qualified technician install a new coil assembly and transistor on main board.
- NOTE: If claw is jerky while being lowered, it is likely that the up spring is missing or has not been slightly elongated properly. Another possibility is that the string has mechanically bound on the spool. To fix the string binding, enter the programming mode and go to mode 24. By moving the joystick to the left and right, you are able to raise and lower the claw mechanism. Move the crane over the prize chute and lower the claw mechanism all the way until it starts to wind up backwards. Reverse the motor direction to raise the claw mechanism and properly rewind the string on the spool. Exit the programming mode and the string should be free of mechanical binding.
- NOTE: If the claw stays open, first check for bad fuses on the main board. Next check that there are no wires dislodged from the connectors in the harness between the wagon and crane, the harness between the wagon and the main board, the crane assembly and the wagon assembly. If the problem still exists, and no fuses are blown or wires dislodged, it is likely that the transistor controlling voltage to the claw has blown on the main board. Have the coil assembly and transistor on the main board replaced by a qualified technician.
- NOTE: If the crane / wagon, in the home position, tries to move left or back, check to see that the actuators are both present. Next, check to see that the sensors are present. Next, check to see that the sensors and actuators are aligned. Then check to see that the sensor wires are not dislodged from the connectors. Finally, replace the sensor, it is likely to be bad.

GAME REPAIR

WARNING: ALWAYS REMOVE POWER FROM THE GAME BEFORE ATTEMPTING ANY SERVICE, UNLESS NEEDED FOR SPECIFIC TESTING. FAILURE TO OBSERVE THIS PRECAUTION COULD RESULT IN SERIOUS INJURY TO YOURSELF AND / OR OTHERS.

TROUBLESHOOTING PHILOSOPHY

To find problems with the game, always check the obvious first. See that the game is plugged in and that all of the fuses are good.

Next, check to see that all of the connectors are firmly seated and that no wires have been pulled out.

When trying to find out if specific components are bad or not, try swapping them with components from another **JEWELRY CRANE™** game, if available, to see if the problem moves with the component or stays where it was. This will help you decide if you have a problem with a specific component or maybe a problem with either the wiring or the main p.c. board. Use extreme caution when using probes or volt meters if the game is powered up. If checking continuity, it is important to disconnect the harnessing at both ends, as attached they may yield erroneous results.

If a p.c. board is suspected as causing your problems, check to see that all of the I.C. chips are firmly seated on the board.

MAIN P.C. BOARD REPLACEMENT

1. Remove all A.C. power from the game
2. Unlock and open the front door
3. Carefully remove all of the connectors from the main p.c. board.
4. Remove the 4 long plastic hexagon nuts that secure the board to the main board housing.
5. Gently pull the p.c. board from the mounting studs.
6. Reassemble in the reverse order using a new main p.c. board.

FRONT GLASS REPLACEMENT

1. Remove all A.C. power from the game.
2. Remove the (3) 10-24 carriage bolts holding the top glass frame in place.
3. Loosen the (5) 1/4-20 kep nuts holding each side glass retainer in place and slide retainers back.
4. Loosen and remove the (3) self tapping screws holding the bottom glass retainer / window valance in place.
5. If the glass is broken, be sure to remove all pieces from where the new glass will rest.
6. With proper ceiling height, slide the new glass in from the top. NOTE: Be careful to proper align the glass with the side channels to prevent breakage.
7. When glass is properly seated, slide the side glass retainers into place and tighten the (5) 1/4-20 kep nuts for each side.
8. Re-install the bottom glass retainer and tighten into place via the (3) self tapping screws
9. Re-install the top window frame and tighten into place via the (3) 10-24 carriage bolts.

SIDE GLASS REPLACEMENT

1. Remove all A.C. power from the game.
2. Remove wagon and crane assemblies.
3. Remove front and rear cabinet rails and hardware.
4. Remove fluorescent lights and brackets on side where glass is to be replaced.
5. Remove (2) side window retainers and (1) top window retainer.
6. Remove side marquee.
7. Back out long 1/4-20 bolts that hold on the side window retainers so they are flush with the 1" tube frame.

GAME REPAIR

8. Remove bolts holding playfield in place near bottom of the glass.
9. Install new glass from the inside of the game and drop into channel in the playfield.
10. Reinstall retainers, lights, brackets, marquee, playfield bolts and rails in reverse order.

PLUSH RETAINER WALL REPLACEMENT

1. Remove all A.C. power from the game.
2. Unlock and open front door
3. Carefully remove the (2) 1/4-20 nuts holding the plastic plush retainer / wall to the side of the game.
4. Remove old plastic plush retainer wall
5. Reassemble in reverse order using new plastic plush retainer wall.

REMOVAL OF CRANE MECHANISM

1. Remove all A.C. power from the game.
2. Unlock and open the front door.
3. Slide the crane assembly to the front center of the game.
4. Loosen black thumb screw securing the front to back micro track bracket in place. The thumb screw is located on the front face of the crane assembly nearest the door.
5. Slide the micro track bracket forward and up to disconnect it from the crane assembly.
6. Carefully lift the entire crane assembly off the rails approximately 2 inches, shift to the left as far as possible, drop the right side down past the right crane rail and slide the entire assembly out from between the two separator rails.
7. The crane assembly can now be removed from the cabinet so necessary maintenance / repairs can be made
8. Reassemble in reverse order.

REMOVAL OF WAGON ASSEMBLY

1. Remove all A.C. power from the game.
2. Unlock and open front door.
3. Remove crane assembly as detailed previously.
4. Loosen black thumb screw securing the micro track bracket in place. The thumb screw is located on the upper right face of the wagon assembly at rear.
5. Slide the micro track bracket to the right and up to disconnect it from the wagon assembly.
6. Carefully lift the entire wagon assembly off the rails and rotate clockwise until the left front wheel clears the front rail.
7. Lower the front of the wagon assembly and remove the assembly from between the two rails.
8. The wagon assembly can now be removed from the cabinet so necessary maintenance / repairs can be made.
9. Reassemble in reverse order.

PRIZE SENSOR REPLACEMENT

1. Remove all A.C. power from the game.
2. Unlock and open the front door.
3. Disconnect the connector to the prize sensor board.
4. Remove the 2 bolts holding the prize sensor bracket to the playfield and remove the prize sensor and bracket from the game.
5. Remove the 2 plastic hexagonal nuts securing the sensor board to the bracket.
6. Carefully remove the sensor board from its mounting studs.
7. Reassemble in reverse order using a new prize sensor board.

GAME REPAIR

STRING REPLACEMENT

1. Remove all A.C. power from the game.
2. Unlock and open front door.
3. Remove crane assembly as previously stated.
4. Disconnect the claw assembly from the crane assembly by removing the two bolts securing the aluminum coil cap to the coil housing.
5. Tie a knot at the end of the replacement string. Use super glue to prevent the knot from working loose or use a lighter to melt the knot to prevent loosening.
6. Using a lighter, melt the other end of the string and form a point before it completely cools.
7. Remove crane housing cap by loosening the (2) thumbscrews.
8. Feed the pointed end up through the hole in the coil cap and pull until the knot is firmly seated on the inside of the cap. SEE CRANE ASSEMBLY DRAWING
9. A proper string routing diagram is located on the bottom side of the crane housing cap.
10. Feed the pointed end up through the hole in the bottom of the crane assembly housing.
11. Feed string over first string guide then under the next string guide.
12. Finally, feed the string through the hole in the side of the string spool, attached to the motor shaft, and tie another knot. (Once again, either use super glue to prevent the knot from working loose or use a lighter to melt the knot to prevent loosening)
13. The string is now properly strung.
14. Re-attach the claw assembly to the crane assembly using the two bolts that were removed in step 4.
15. Re-install the crane assembly into the game and set it in the home position with the claw assembly hanging in the prize chute.
16. Turn on the game and the crane will automatically rewind the string properly.

MOTOR REPLACEMENT

1. Remove all A.C. power from the game.
2. Unlock and open front door.
3. Remove crane and / or wagon assembly as previously stated. NOTE: What is removed depends on which motor has gone bad.
4. Loosen two thumb screws securing crane housing cap in place and remove. NOTE: This step is only for the 2 motors in the crane assembly.
5. Remove drive o-rings and wheels from the bad motor.
6. De-solder the motor leads from the bad motor. NOTE: Be sure to note which wire goes to which motor lead, for if they are re-installed backwards, the motor will run opposite of its intended direction.
7. Carefully remove the bronze bushing supporting the motor shaft of the bad motor. NOTE: This step is only for the 2 motors in the crane assembly.
8. Remove the 4 bolts securing the motor to the housing.
9. Carefully remove the bad motor.
10. Re-assemble in reverse order using new motor. NOTE: When motor is completely re-installed, place one drop of thread lock on each of the 4 bolts that secure the motor in place to prevent the bolts from backing out.

PRECAUTION

When installing a new motor in any of the three locations, please note that the 4 screws, if tightened too much, could mis-align the motor and cause binding. It is advisable that you tighten the 4 screws just enough to keep the motor from moving. Then apply a small drop of (Blue) loctite on the back side of each of the 4 screws to prevent the screws from loosening. When the motor is installed properly, it should draw .5 amps or less when running at proper 22 volts.

GAME REPAIR

FUSE REPLACEMENT

CAUTION FOR CONTINUED PROTECTION AGAINST RISK OF FIRE. REPLACE ONLY WITH THE SAME TYPE OF FUSE HAVING THE SAME ELECTRICAL RATING.

<u>AREA</u>	<u>LOCATION</u>	<u>AMP</u>	<u>VOLT</u>
MAIN BOARD	F2	6 MDQ	250
	F3	3 MDQ	250
	F4	4 MDQ	250
POWER MOD	—	3 MDQ	250
ROPE LIGHT CONTROLLER	—	3 MDQ	250

CORD REPLACEMENT

IF THE SUPPLY CORD IS DAMAGED, IT MUST BE REPLACED BY THE MANUFACTURER OR ITS SERVICE AGENT OR A SIMILARLY QUALIFIED PERSON IN ORDER TO AVOID A HAZARD.

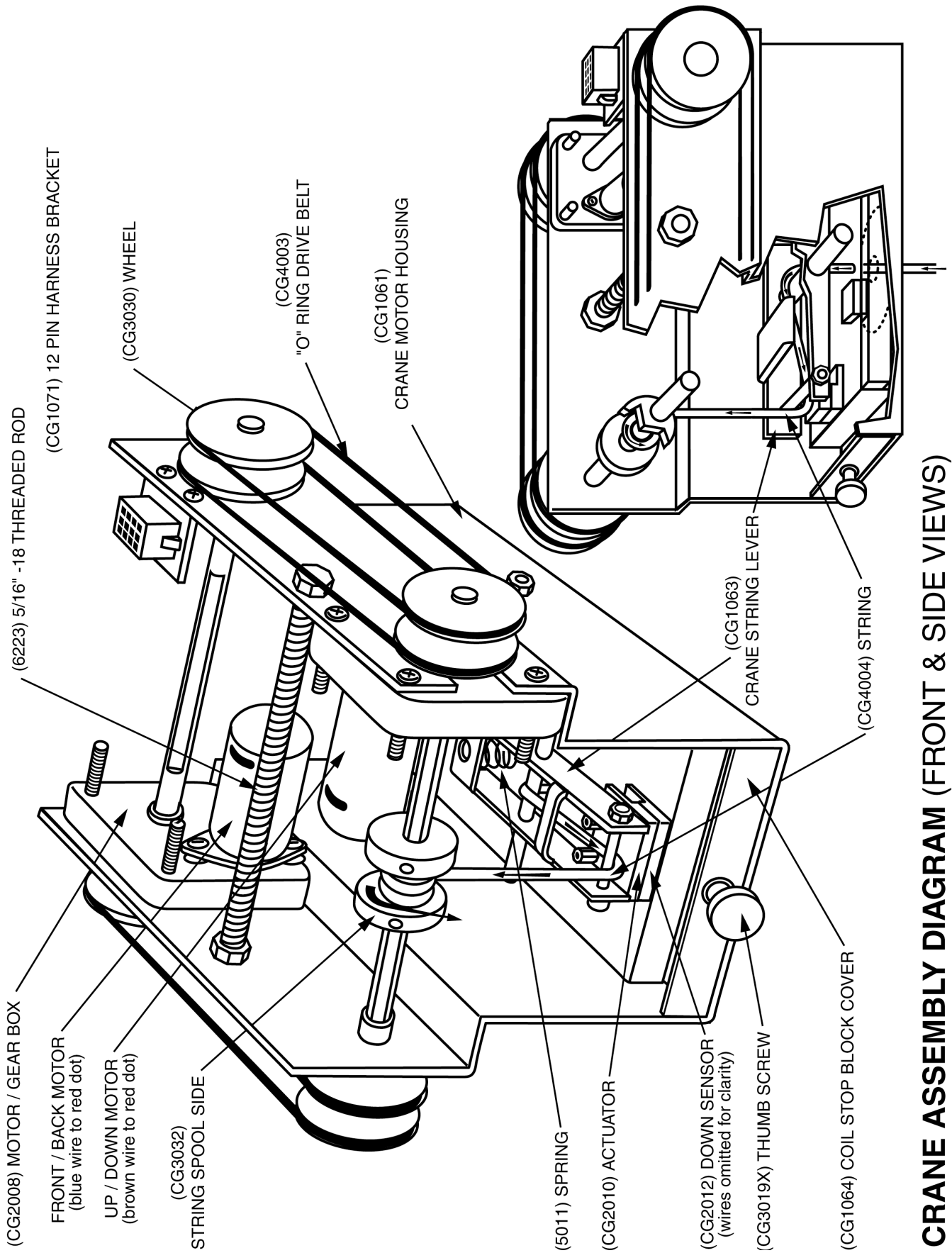

CRANE ASSEMBLY DIAGRAM (FRONT & SIDE VIEWS)

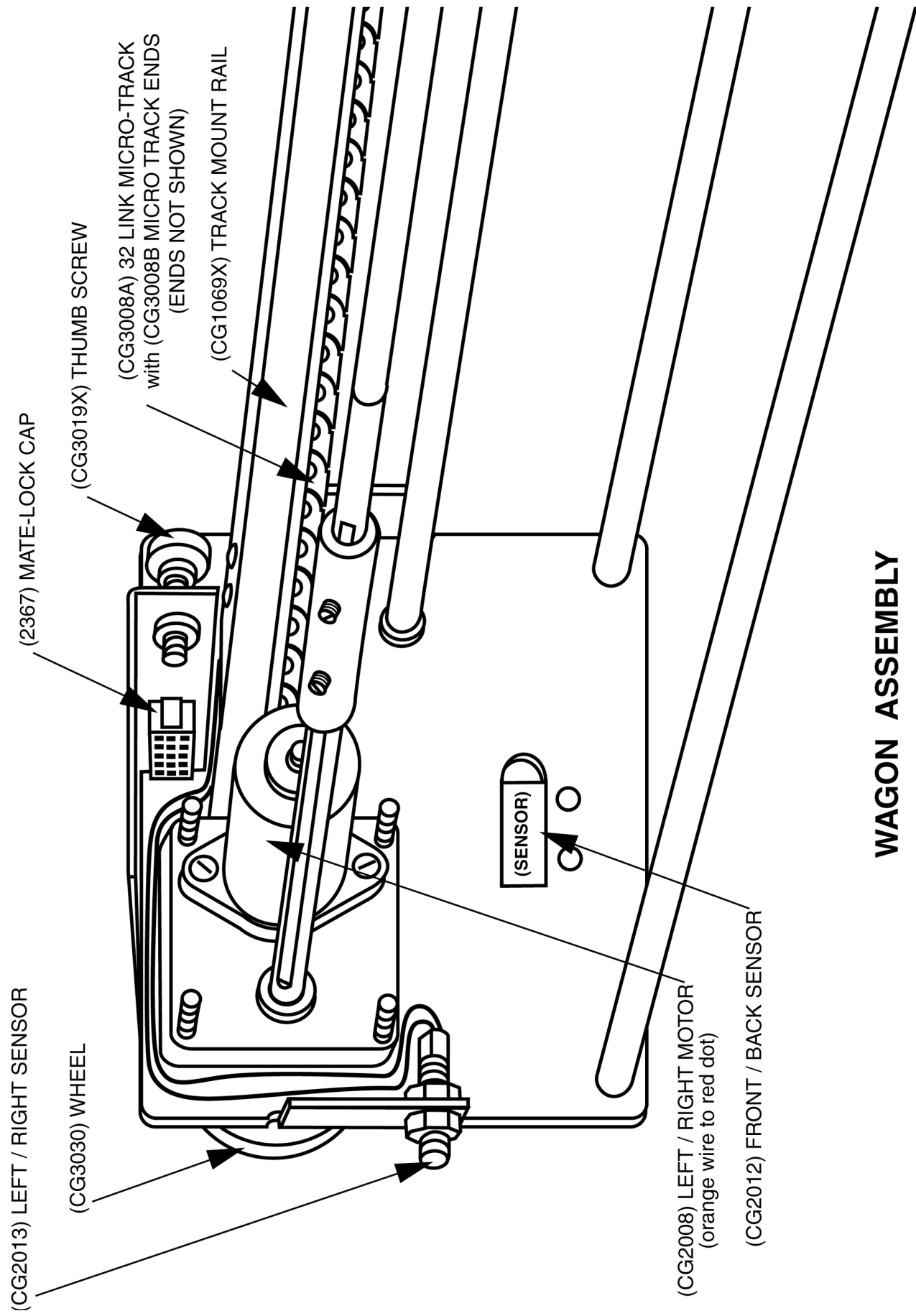

WAGON ASSEMBLY

CLAW ASSEMBLY

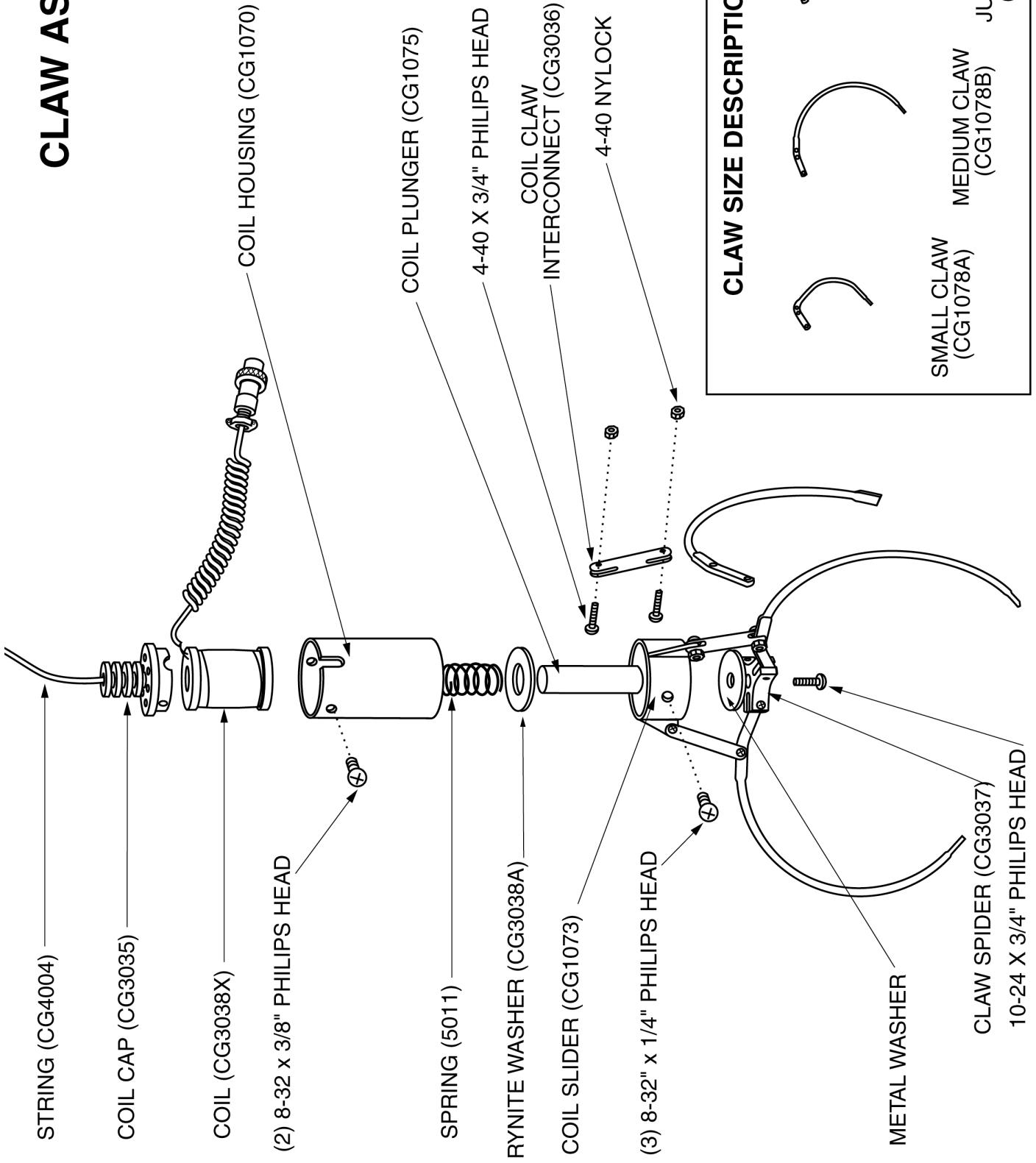

STRING ROUTING DIAGRAM

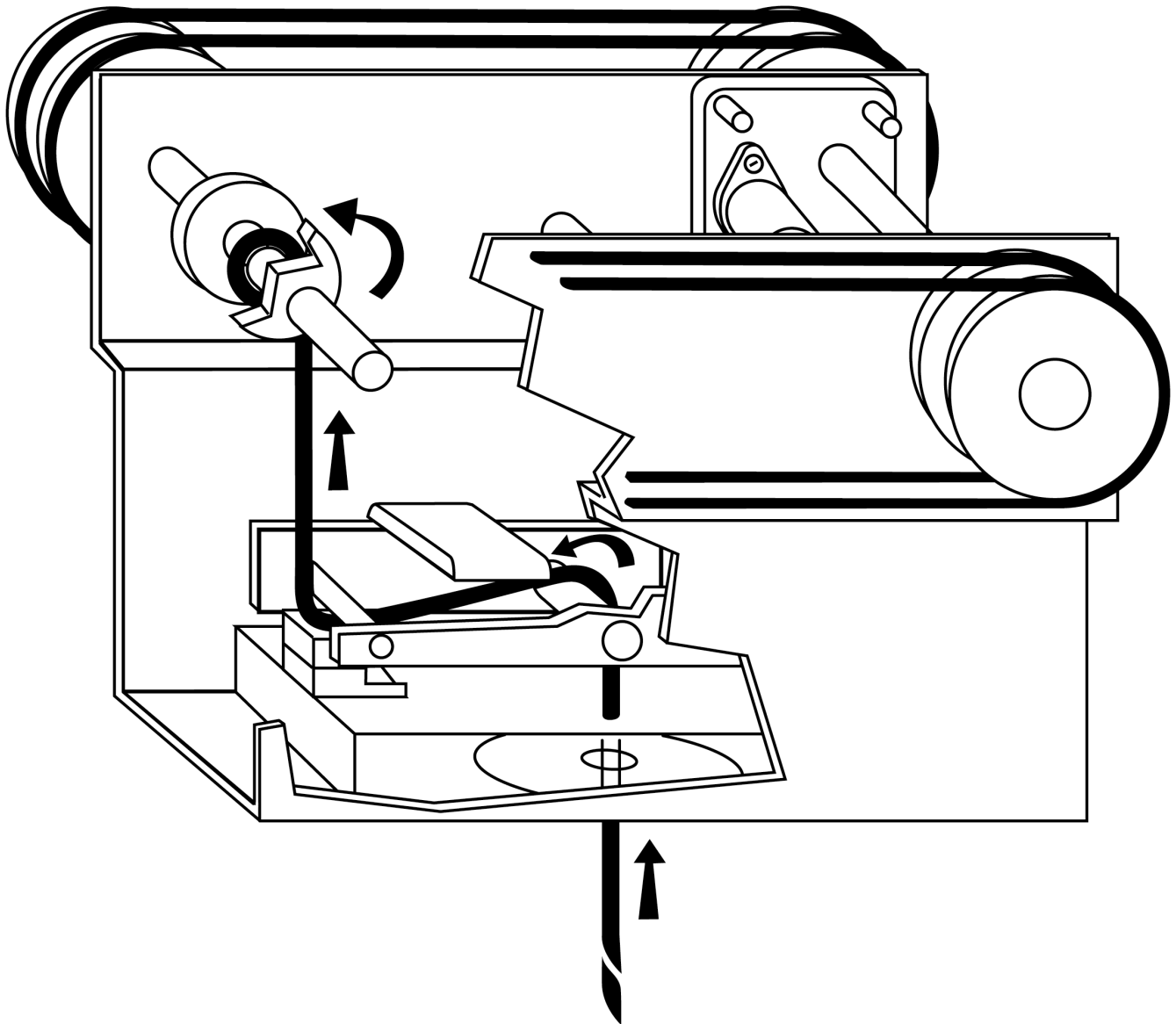

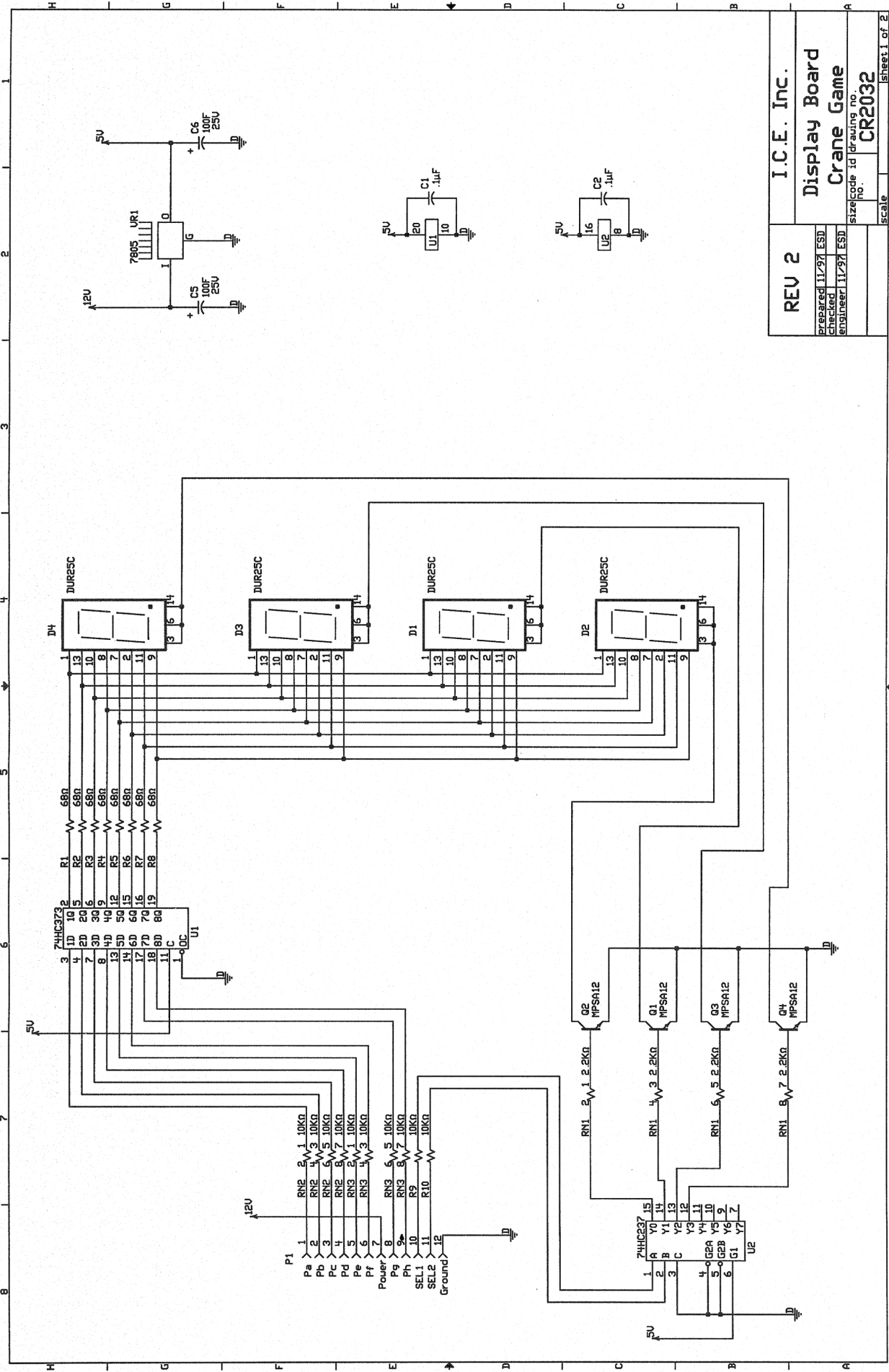

REV 2		I.C.E. Inc.	
Prepared	11/97 ESD	Display Board	
Checked	engineer	Crane Game	
Engineer	11/97 ESD	size	code id
		no.	drawing no.
		CR2032	
		scale	sheet 1 of 2

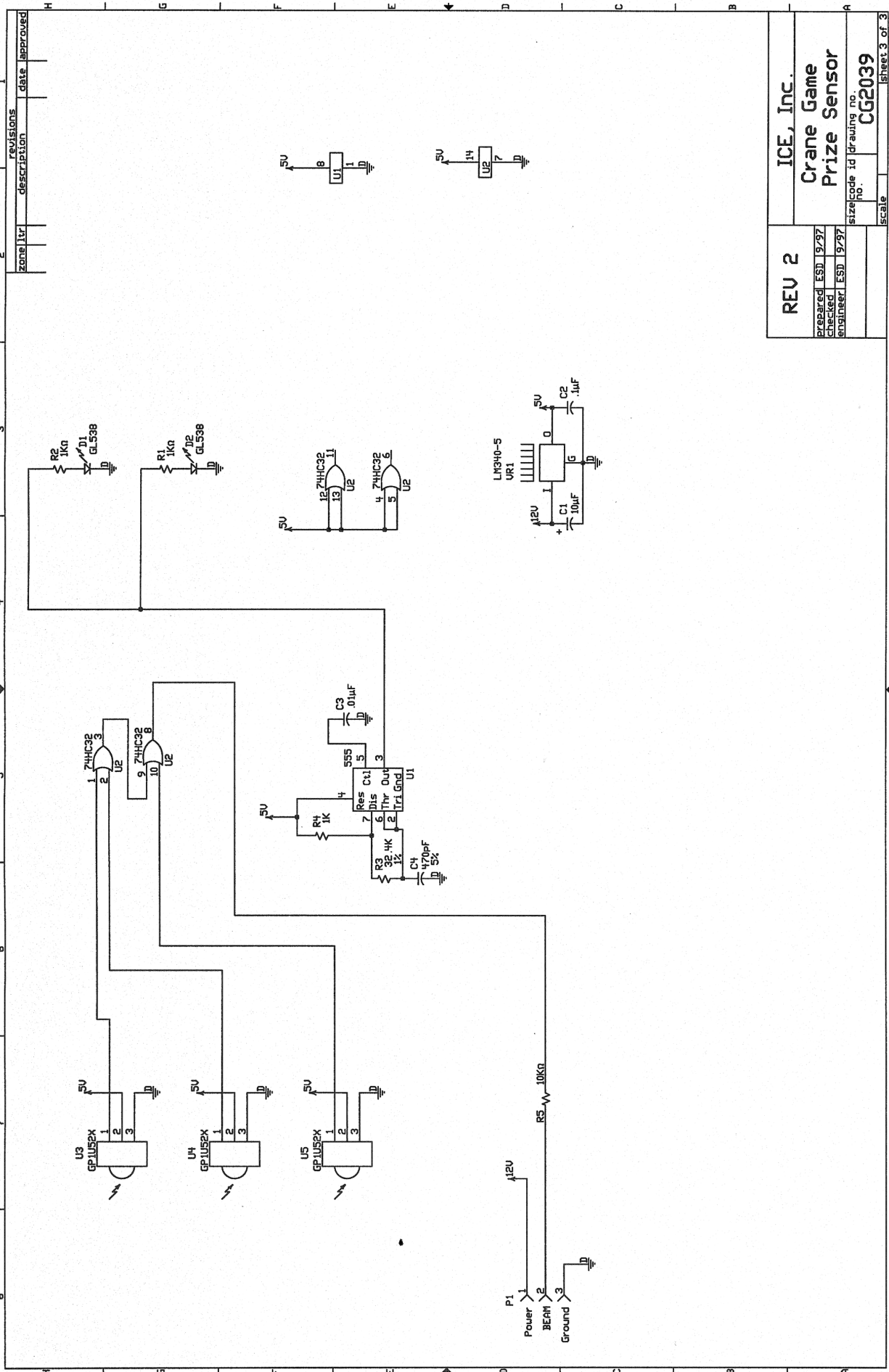

zone	itr	description	date	approved

REV 2		ICE, Inc.	
Prepared	ESD 19/97	Crane Game	
Checked	ESD 19/97	Prize Sensor	
Engineer	ESD 19/97	size code id drawing no.	
		CG2039	
		scale	sheet 3 of 3

P1

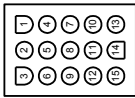

CARRIAGE

- 1. MOTOR UP
- 2. MOTOR DOWN
- 3. HOME LEFT / RIGHT SENSOR
- 4. CLAW UP SENSOR
- 5. CLAW DOWN SENSOR
- 6. CLAW CLOSE (CLAW -)
- 7. GROUND
- 8. GROUND
- 9. MOTOR RIGHT
- 10. MOTOR BACK
- 11. HOME FRONT / BACK SENSOR
- 12. MOTOR LEFT
- 13. MOTOR FORWARD
- 14. CLAW POWER (CLAW+)
- 15. 36V

P2



REMOTE

- 1. GROUND
- 2. PROGRAM BUTTON
- 3. ACCOUNTING
- 4. GROUND
- 5. AUDIO TOP
- 6. AUDIO WIPER

P3



TICKETS

- 1. TICKET SENSE
- 2. GROUND
- 3. TICKET RUN
- 4. 12VOLTS

P4



PRIZE SENSOR

- 1. 12 VOLTS
- 2. PRIZE SENSOR
- 3. GROUND

P6

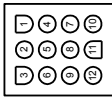

DISPLAY

- 1. SEGMENT A
- 2. SEGMENT B
- 3. SEGMENT C
- 4. SEGMENT D
- 5. SEGMENT E
- 6. SEGMENT F
- 7. 12 VOLTS
- 8. SEGMENT H
- 9. SEGMENT G
- 10. SELECT 1
- 11. SELECT 2
- 12. GROUND

P7



LIGHTS

- 1. 12 VOLTS
- 2. 12VOLTS
- 3. 12VOLTS
- 4. DOOR SWITCH
- 5. 12VOLTS
- 6. HEADLIGHTS
- 7. LEFT BLINKER
- 8. RIGHT BLINKER
- 9. GROUND

P8



COUNTERS

- 1. PRIZE COUNTER
- 2. 5VOLTS
- 3. MCOIN / CREDIT COUNTER

P9

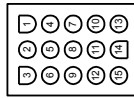

DOOR

- 1. JOYSTICK UP
- 2. JOYSTICK DOWN
- 3. JOYSTICK RIGHT
- 4. JOYSTICK LEFT
- 5. JOYSTICK BUTTON
- 6. COIN INPUT
- 7. GROUND
- 8. GROUND
- 9. GROUND
- 10. DOLLAR BILL VALIDATOR
- 11. SPEAKER +
- 12. SPEAKER -
- 13. 12 VOLTS
- 14. KEY
- 15. GROUND

P10



POWER

- 1. KEY
- 2. 16 VAC
- 3. 10 VAC
- 4. 36 VAC
- 5. 10 VAC
- 6. 13 VAC
- 7. 36 VAC
- 8. 16 VAC
- 9. 13 VAC

TITLE

DESCRIPTION

CRANE MAIN BOARD
CONNECTOR PIN OUT

FILENAME

PLUSH3.VSD

DRAWN BY

RMO

DATE

2/19/98

REVISED

11/15/00

PAGE

2 OF 17

1 2 3 4

D C B A

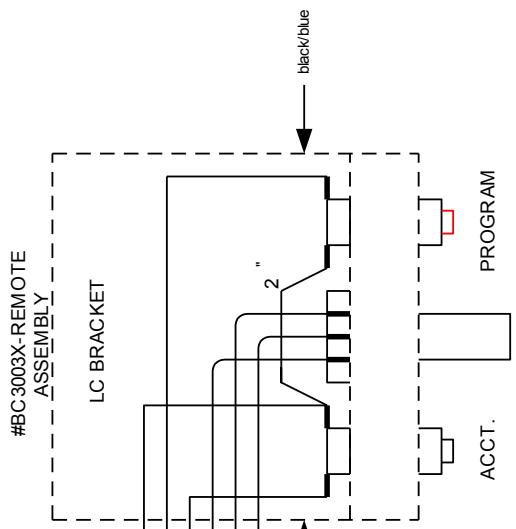

REMOTE P2

1	black	21
2	black/blue	21
3	white/gray	19
4	black	22
5	red/white	22
6	red/black	22

#BC2059X-REMOTO HARNESS

6 PIN PLUG #2173
SOLID PIN #2100S

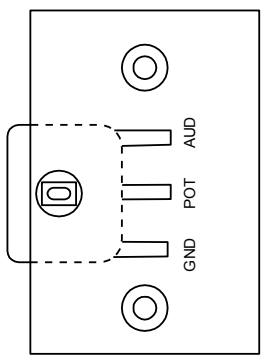

TITLE		BASIC CRANE #BC3003X	
DESCRIPTION	FILENAME	BASIC.VSD	
	DRAWN BY	CMZCMZ	
DATE	3/22/99	REVISED	7/3/01
	2	PAGE	1 OF 6

1 2 3 4

D C B A

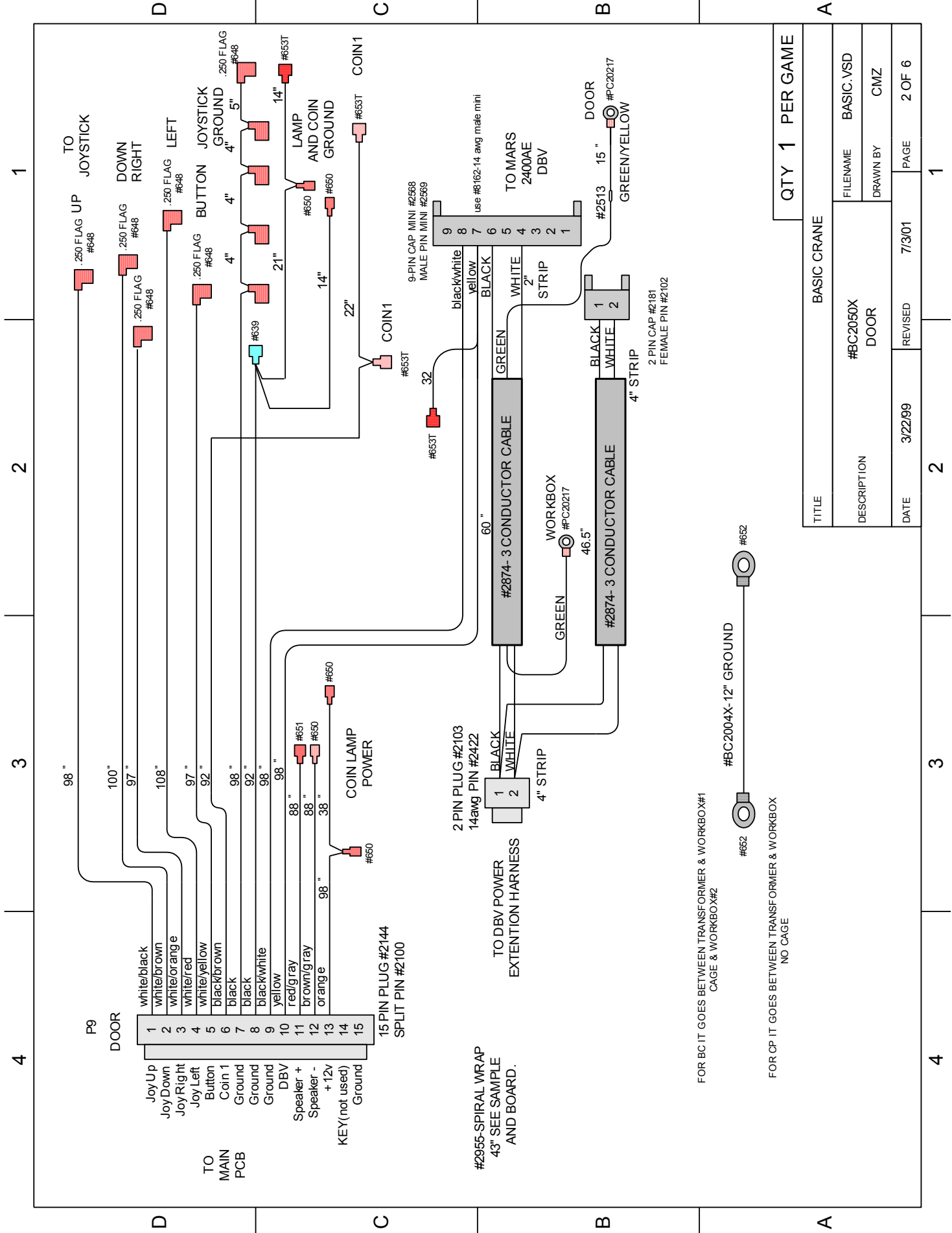

TITLE		BASIC CRANE		QTY 1 PER GAME	
DESCRIPTION		#BC2050X DOOR		FILENAME	BASIC.VSD
DATE		3/22/99		DRAWN BY	CMZ
REVISED		7/3/01		PAGE	2 OF 6

FOR BC IT GOES BETWEEN TRANSFORMER & WORKBOX#1 CAGE & WORKBOX#2

FOR CP IT GOES BETWEEN TRANSFORMER & WORKBOX NO CAGE

1 2 3 4

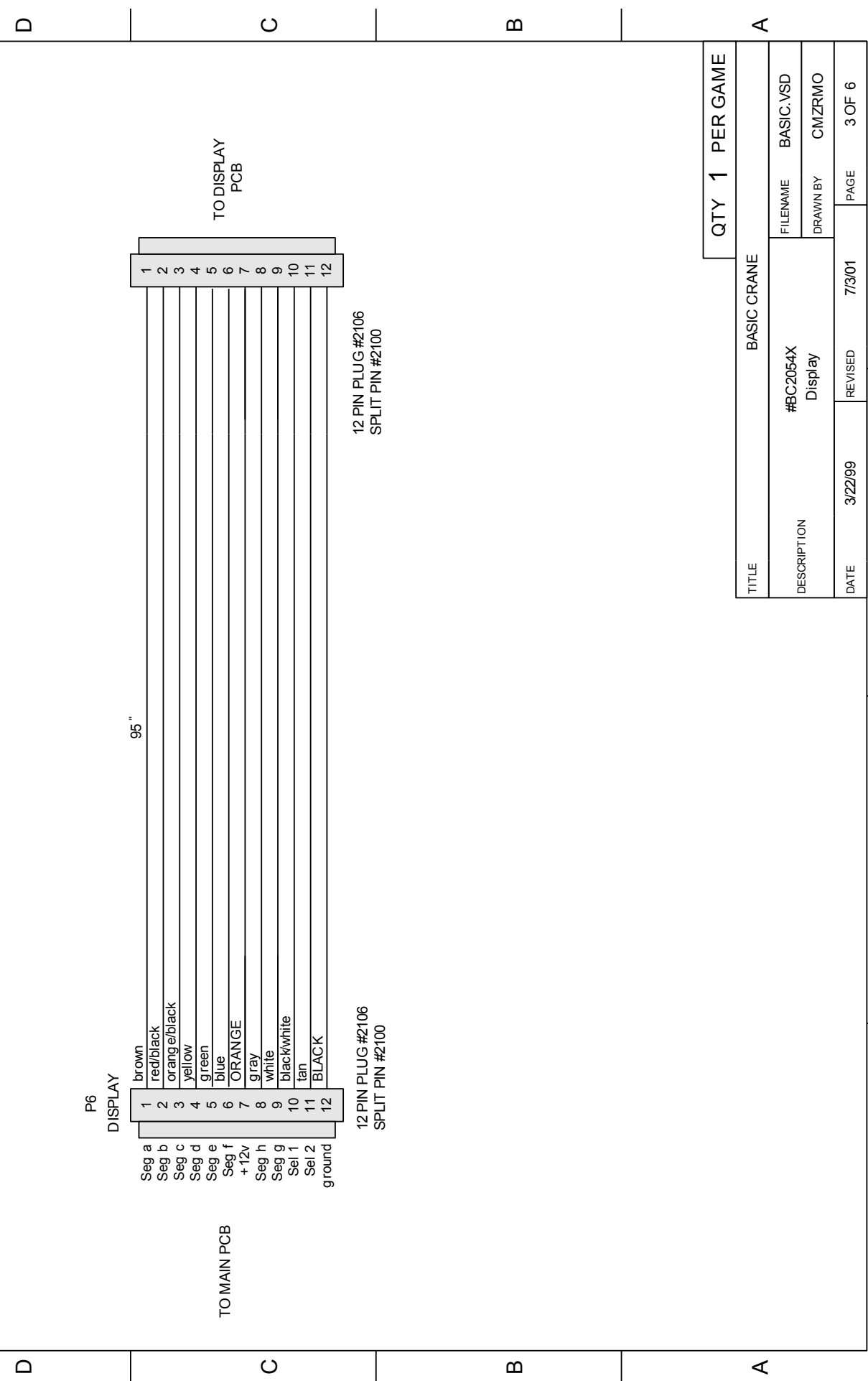

1 2 3 4 5 6 7 8 9 10 11 12

12 PIN PLUG #2106
SPLIT PIN #2100

P6
DISPLAY
1 brown
2 red/black
3 orange/black
4 yellow
5 green
6 blue
7 ORANGE
8 gray
9 white
10 black/white
11 tan
12 BLACK
12 PIN PLUG #2106
SPLIT PIN #2100

95"

TO MAIN PCB

TO DISPLAY
PCB

QTY 1 PER GAME			
A			
TITLE		BASIC CRANE	
DESCRIPTION		#BC2054X Display	FILENAME BASIC.VSD
DATE		3/22/99	DRAWN BY CMZFRMO
		REVISED	PAGE
		7/3/01	3 OF 6

1 2 3 4

1 2 3 4

D D

C C

B B

A A

P7

- 1
- 2
- 3
- 4
- 5
- 6
- 7
- 8
- 9

yellow/black

40"



#651

black

40"



#651

9 PIN PLUG #2292
SOLID PIN #2100S

QTY 1 PER GAME

TITLE		BASIC CRANE	
DESCRIPTION		#BC2058X	DOOR INTERLOCK
DATE	3/22/99	REVISED	7/3/01
FILENAME	BASIC.VSD	DRAWN BY	CMZRM0
PAGE	5 OF 6		

1 2 3 4

4 3 2 1

D C B A

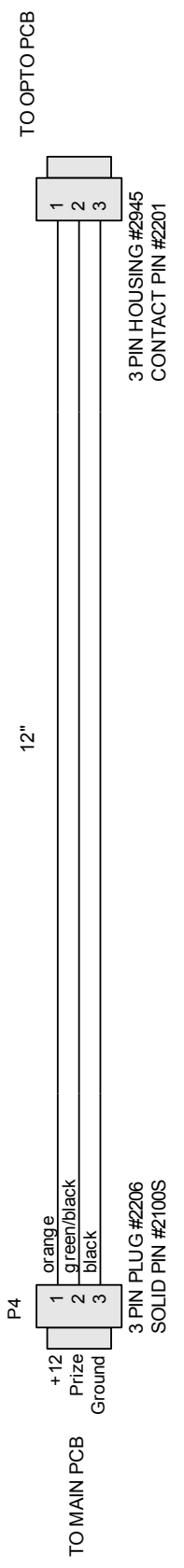

QTY 1 PER GAME			
BASIC CRANE			
TITLE	BASIC.VSD		
DESCRIPTION	#BC2060X Opto	FILENAME	BASIC.VSD
DATE	3/22/99	DRAWN BY	CMZ/MO
	REVISED	7/3/01	PAGE 6 OF 6

4 3 2 1

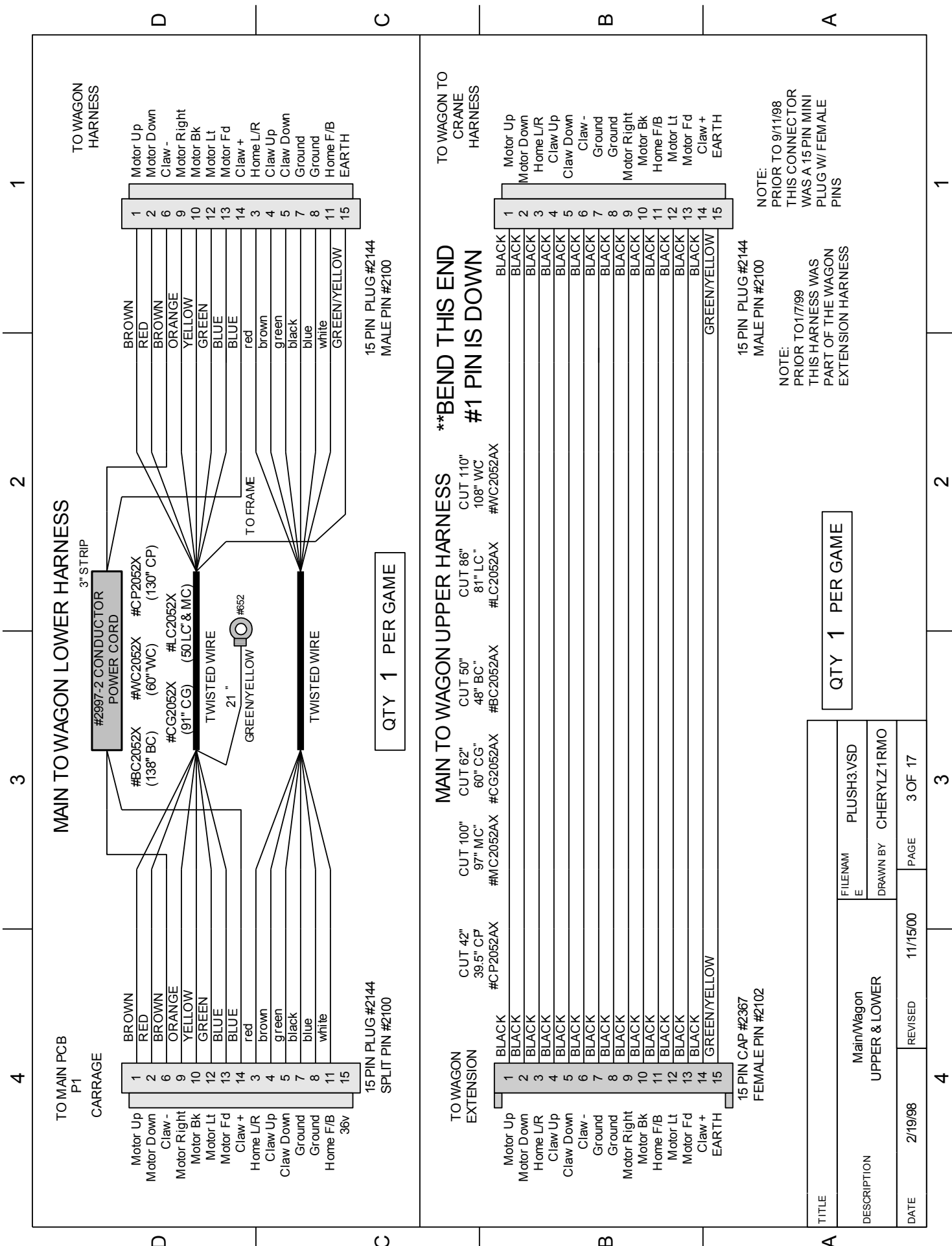

MAIN TO WAGON LOWER HARNESS

TO MAIN PCB
P1
CARRIAGE

TO WAGON
HARNESS

- | | | |
|----|--------|-------------|
| 1 | BROWN | Motor Up |
| 2 | RED | Motor Down |
| 6 | BROWN | Claw - |
| 9 | ORANGE | Motor Right |
| 10 | YELLOW | Motor Bk |
| 12 | GREEN | Motor Lt |
| 13 | BLUE | Motor Fd |
| 14 | BLUE | Claw + |
| 3 | red | Home L/R |
| 4 | brown | Claw Up |
| 5 | green | Claw Down |
| 7 | black | Ground |
| 8 | blue | Ground |
| 11 | white | Home F/B |
| 15 | white | EARTH |
- 15 PIN PLUG #2144
SPLIT PIN #2100
- TO FRAME
- TO WAGON HARNESS

QTY 1 PER GAME

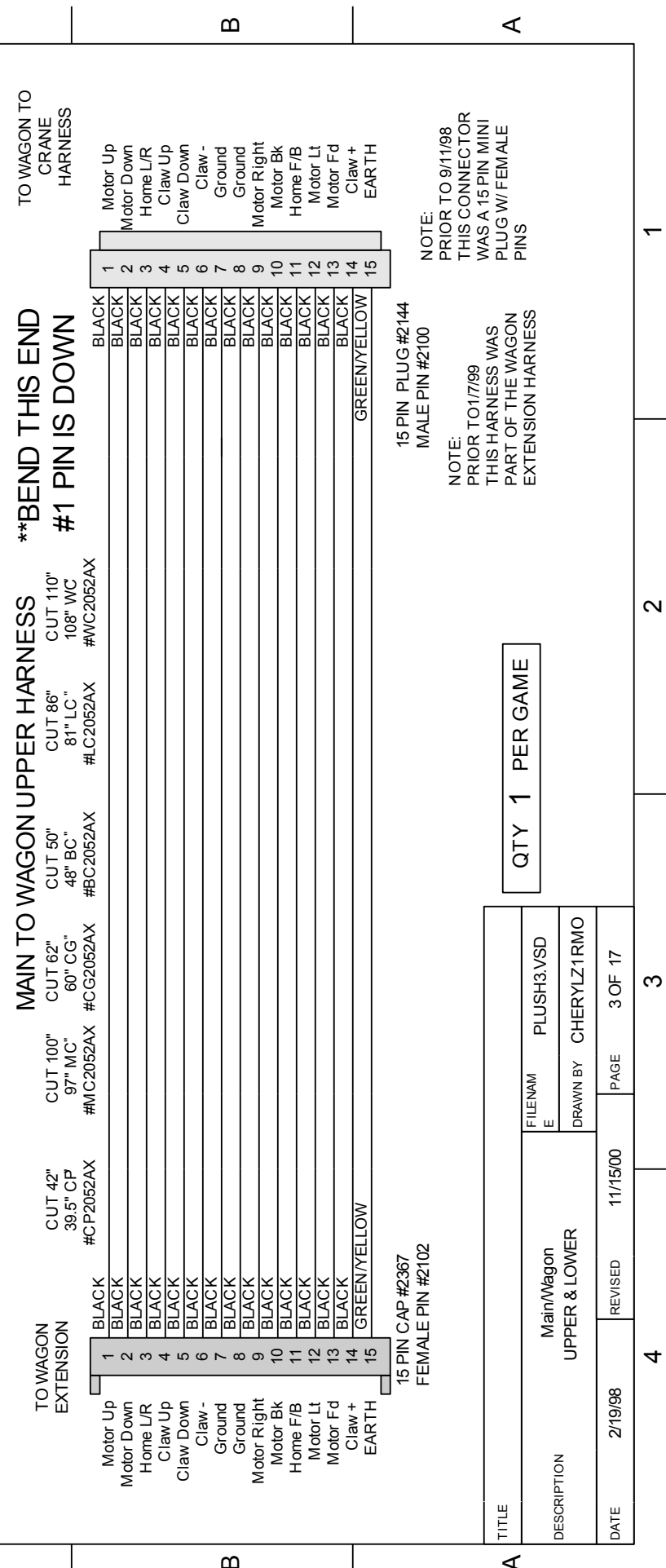

MAIN TO WAGON UPPER HARNESS

TO WAGON TO
CRANE
HARNESS

TO WAGON
EXTENSION

- | | | |
|----|--------------|-------------|
| 1 | BLACK | Motor Up |
| 2 | BLACK | Motor Down |
| 3 | BLACK | Home L/R |
| 4 | BLACK | Claw Up |
| 5 | BLACK | Claw Down |
| 6 | BLACK | Claw - |
| 7 | BLACK | Ground |
| 8 | BLACK | Ground |
| 9 | BLACK | Motor Right |
| 10 | BLACK | Motor Bk |
| 11 | BLACK | Home F/B |
| 12 | BLACK | Motor Lt |
| 13 | BLACK | Motor Fd |
| 14 | BLACK | Claw + |
| 15 | GREEN/YELLOW | EARTH |
- 15 PIN PLUG #2144
MALE PIN #2100
- TO WAGON HARNESS

****BEND THIS END
#1 PIN IS DOWN**

QTY 1 PER GAME

FILENAM	PLUSH3.VSD
DRAWN BY	CHERYLZ1RMO
DATE	2/19/98
REVISED	11/15/00
PAGE	3 OF 17

NOTE:
PRIOR TO 9/11/98
THIS CONNECTOR
WAS A 15 PIN MINI
PLUG W/ FEMALE
PINS

NOTE:
PRIOR TO 1/7/99
THIS HARNESS WAS
PART OF THE WAGON
EXTENSION HARNESS

4 3 2 1

FOR 60" SL SINGLE DO THE HIGHLIGHTED AREAS!

MOVE OVER ON CRANE ASY

TO MAIN TO WAGON HARNESS

34.5" (CUT 36")
CG2053X BC



30" (CUT AT 32")
LC2053X

TO CRANE HARNESS

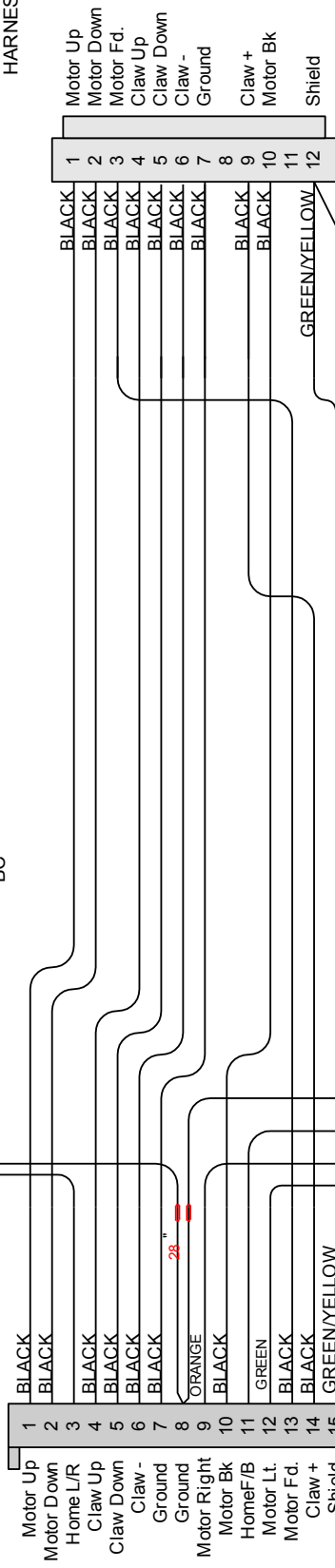

15 PIN CAP #2367
FEMALE PIN #2102
PIN #15 USE #2013-14 AWG

31.5" #2835- SHIELD

GREEN/YELLOW 5" 12 PIN PLUG #2106 Male Pin #2100



NOTE:
PRIOR TO 9/11/98
THIS CONNECTOR WAS A 15 PIN MINI CAP
W/ MALE PINS #8162-20-16 AWG MINI

NOTE: SHIELD
REQUIRED FOR CE
GAMES ONLY

USE A #2422-14 AWG
MALE PIN WHEN
USING SHIELD
IN PIN 12.

NOTE:
PRIOR TO 9/11/98
THIS CONNECTOR WAS A 12 PIN MINI
PLUG WITH FEMALE PINS #8163-MINI

D C B A

QTY 1 PER GAME

TITLE	#CG2053X	
DESCRIPTION	Wagon /Crane	FILENAM E PLUSH3.VSD
DATE	2/19/98	DRAWN BY CERYLZ1RMO
	REVISED	11/15/00
		PAGE 4 OF 17

4 3 2 1

4 3 2 1

D C B A

TO WAGON TO
CRANE
HARNESS

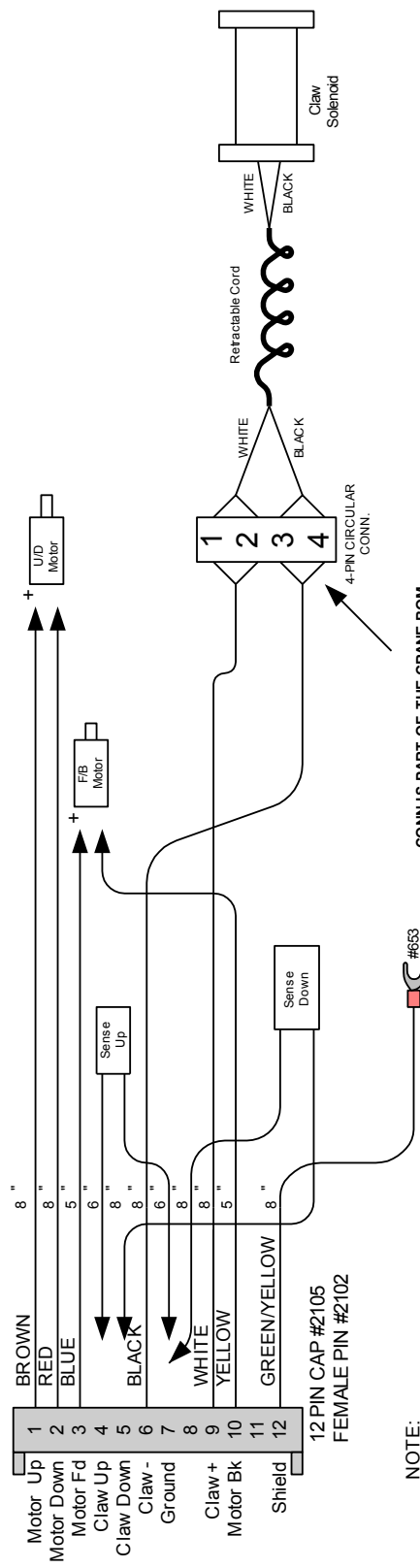

NOTE:
PRIOR TO 9/11/98
THIS CONNECTOR
WAS A 12 PIN MINI
CAP WITH MALE PINS

NOTE:
CONN IS PART OF THE CRANE BOM
SUB ASY SOLDERS THE WIRES FOR
THE MOTORS DIRECT AND ADDS THE
PINS ON THE SENSORS MAKING THOSE
PARTS PART OF THE CRANE BOM!

QTY 1 PER GAME

TITLE	#CG2056X	
DESCRIPTION	Crane	FILENAM E PLUSH3.VSD
DATE	2/19/98	DRAWN BY CHERYLZ1RMO
	REVISED	11/15/00
	PAGE	5 OF 17

4 3 2 1

1 2 3 4

D C B A

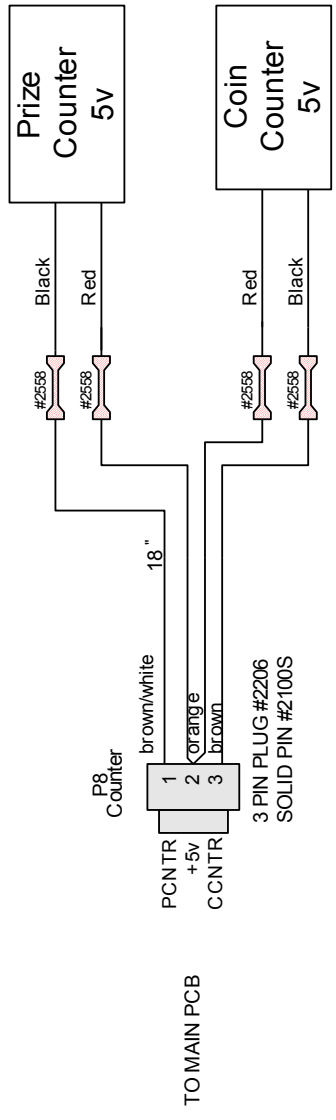

TITLE	#CG2063X	
DESCRIPTION	Counter	FILENAM E PLUSH3.VSD
DATE	2/19/98	DRAWN BY CHERYLZ1RMO
REVISED	11/15/00	PAGE 12 OF 17

QTY 1 PER GAME

1 2 3 4

1 2 3 4

TRANSFORMER #CG2002
120v PRIMARY MCI# 2-51-9813

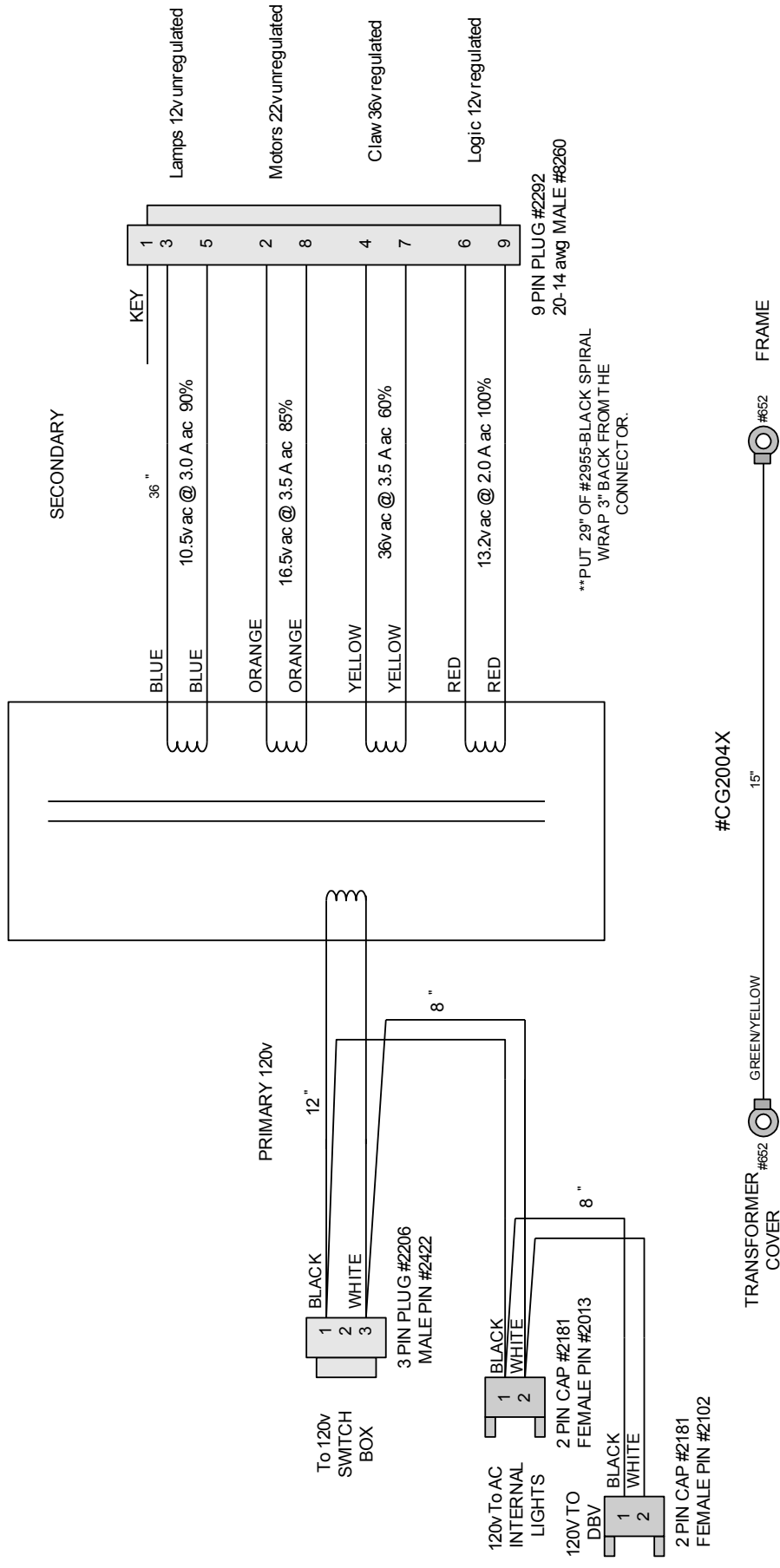

TITLE		#CG2002X/CG2004X	
DESCRIPTION	110v Transformer	FILENAM E	PLUSH3.VSD
DATE	2/19/98	DRAWN BY	CHERYLZ1RMO
	REVISED	11/15/00	PAGE 14 OF 17

1 2 3 4

1 2 3 4

D C B A

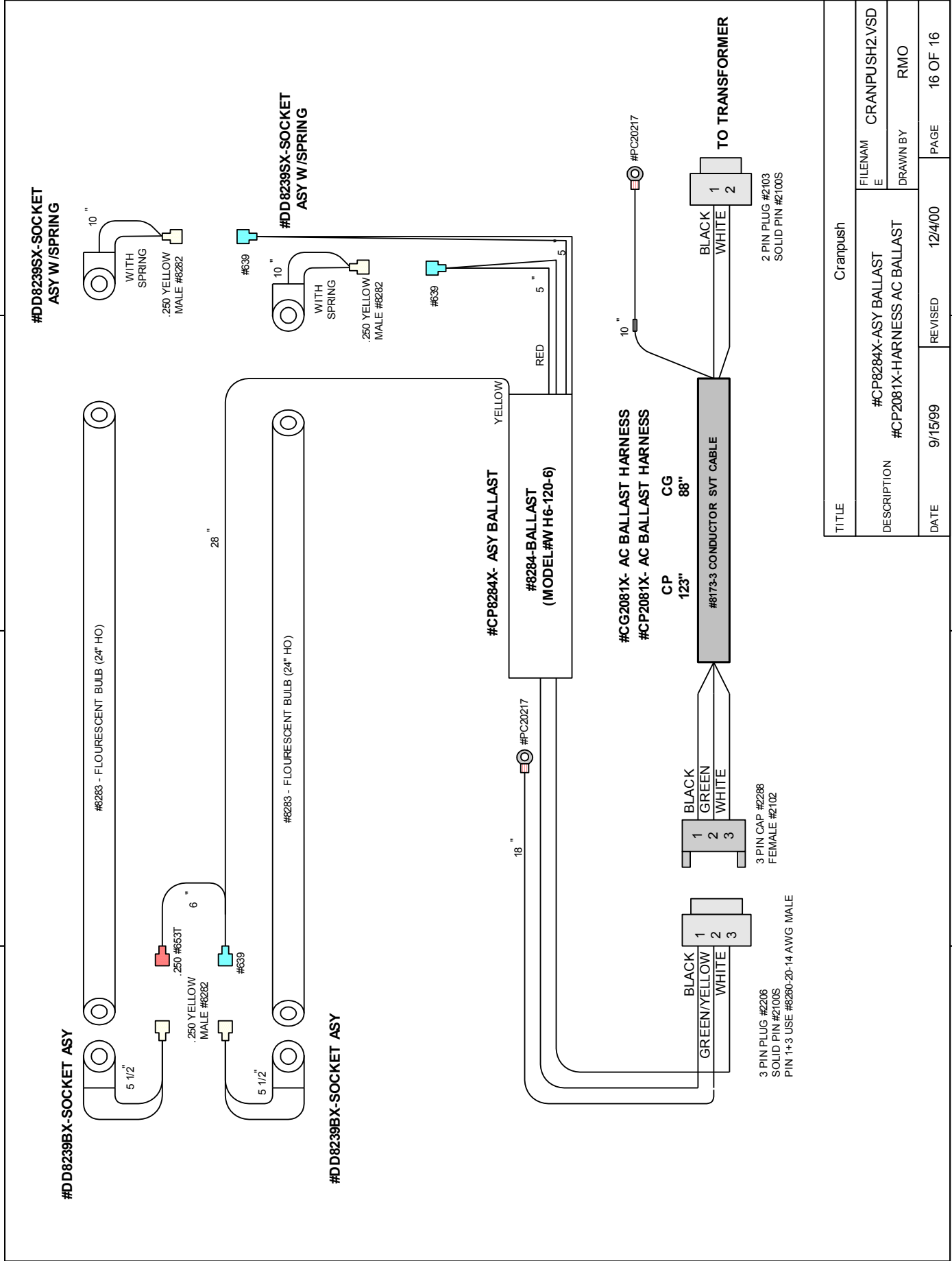

TITLE	Cranpush	
DESCRIPTION	#CP8284X-ASY BALLAST #CP2081X-HARNESS AC BALLAST	FILENAM E CRANPUSH2.VSD
DATE	9/15/99	DRAWN BY RMO
REVISED	12/4/00	PAGE 16 OF 16

1 2 3 4

4 3 2 1

D C B A

#CG2062X-FANTICKET EXTENSION HARNESS

#CG2064X-FAN HARNESS

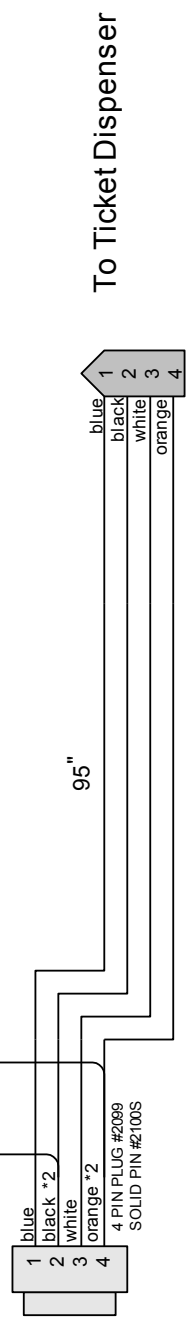
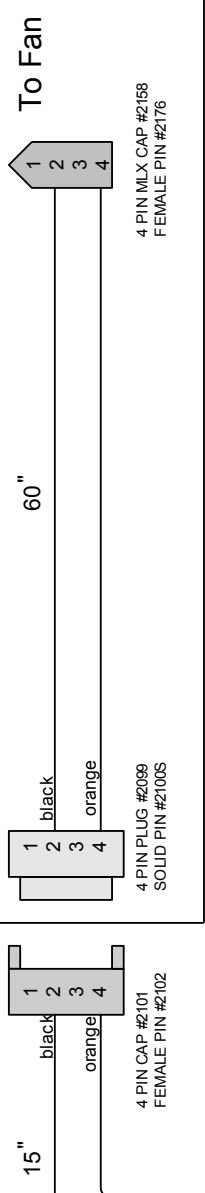

TITLE	FanTicket Extension		
DESCRIPTION	FILENAME	FANTICKET.VSD	
DATE	DRAWN BY	MMARTIN	
2/16/01	REVISED	2/27/01	PAGE 1 OF 1

4 3 2 1

4 3 2 1

#LC2054X-DISPLAY HARNESS

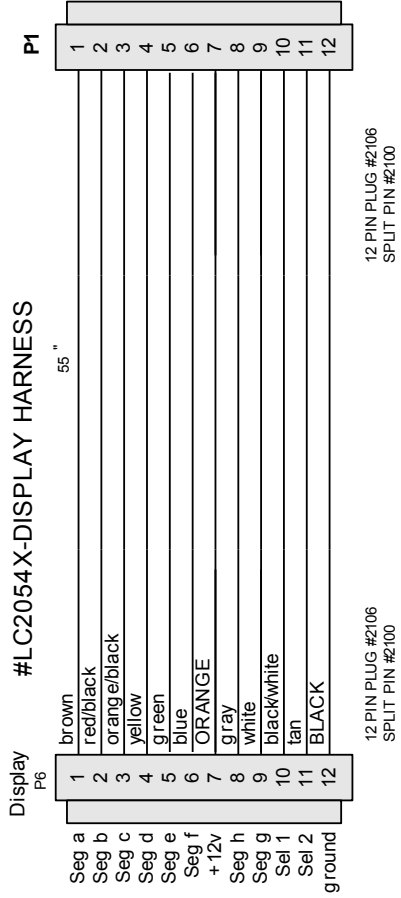

#LC2058X-DOOR INTERLOCK

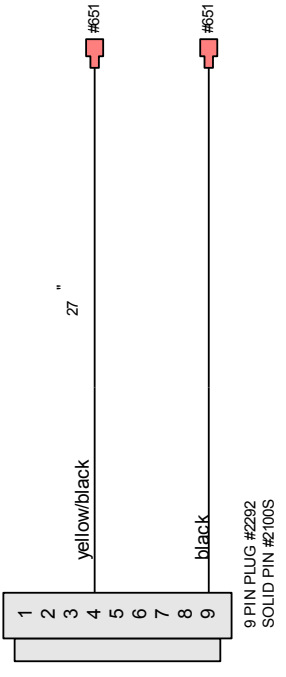

#LC2063X-COUNTER

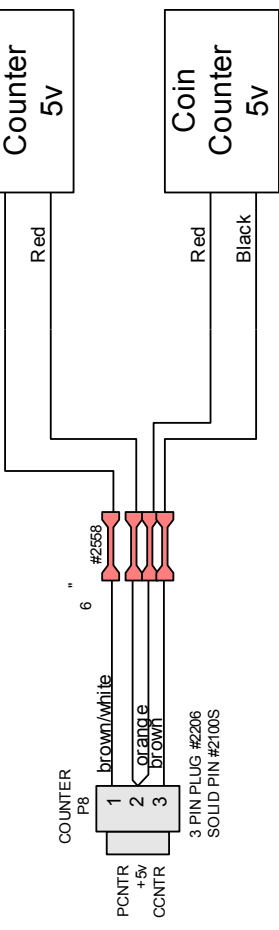

#LC2055X-POWER BOX HARNESS

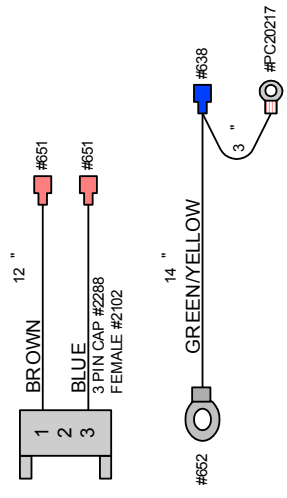

D C B A

TITLE	FILENAM	LC.VSD
DESCRIPTION	E	LITTLE CRANE
DATE	DRAWN BY	RMORMO
7/2/98	REVISED	8/31/00
	PAGE	2 OF 4

4 3 2 1

1 2 3 4

D C B A

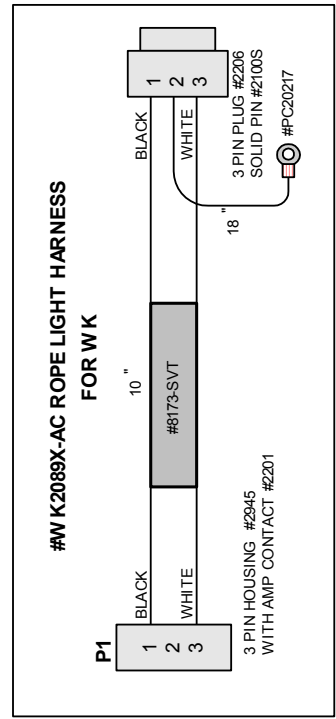
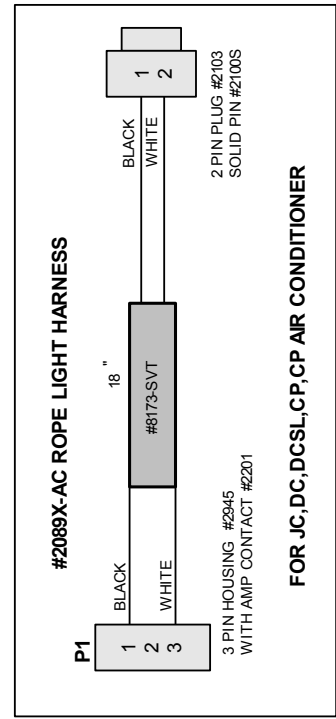
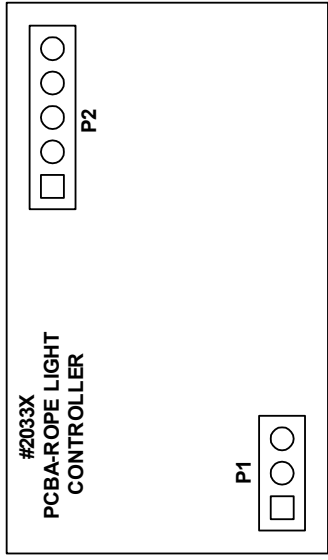
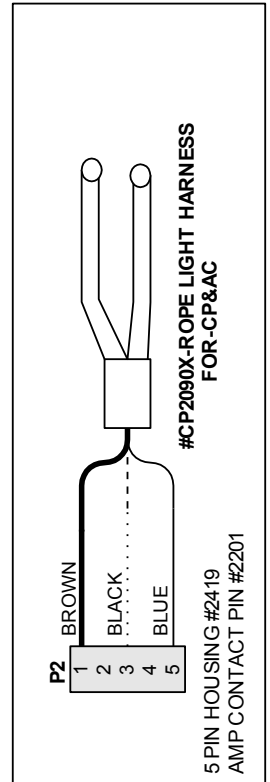
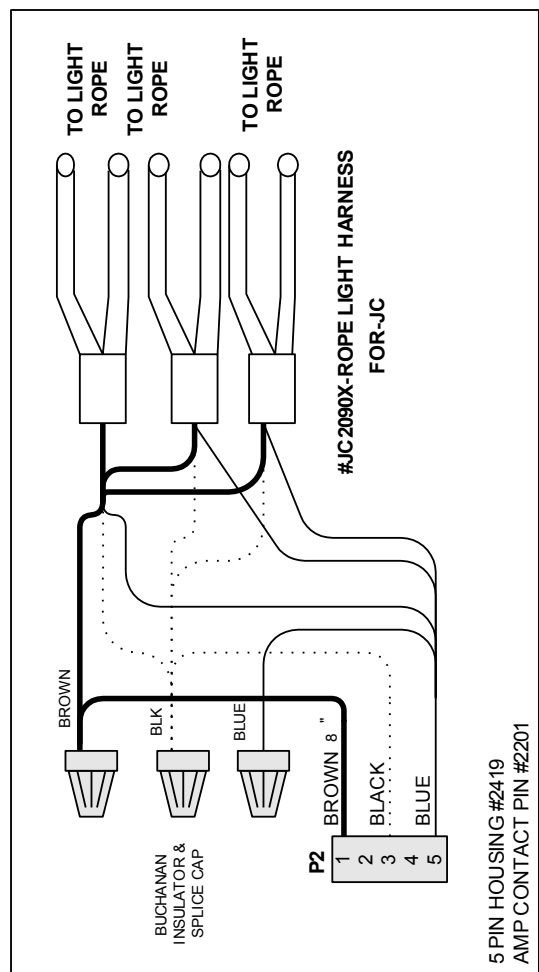
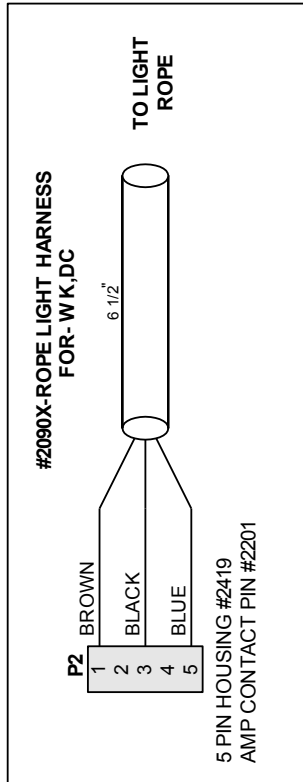

TITLE	LIGHT ROPE CONTROLLER	
DESCRIPTION	FILENAM E	CONTROLLER.VS
DATE	DRAWN BY	CHERYLZ1
6/23/00	REVISED	12/6/00
	PAGE	1 OF 1

1 2 3 4



WARRANTY POLICY

I.C.E. Inc warrants all components in new machines to be free of defects in materials and workmanship for the period listed below:

- 180 days on Main PCB's, Computers & Motors
- 1 year on all LCD monitor panels
- 90 days on all other electronic and mechanical components
- 30 days on all I.C.E. repairs and parts purchases

I.C.E. Inc shall not be obligated to furnish a warranty request under the following conditions:

- Equipment or parts have failed through normal wear and tear
- Equipment has been subjected to unwarranted stress, abuse or neglect
- Equipment has been damaged as a result of arbitrary repair/modification

Products will only be covered under warranty by obtaining an I.C.E. authorized RMA #. To obtain an RMA # please provide I.C.E. tech support with the game serial # or original I.C.E. invoice # and a detailed description of the failure or fault symptoms.

I.C.E. Inc will assume no liability whatsoever for costs associated with labor or travel time to replace defective parts. All defective warranty covered components will be replaced with new or factory refurbished components equal to OEM specifications.

I.C.E. Inc will cover domestic UPS ground, or comparable shipping costs during the warranty period. International or expedited shipments are available for an additional charge. To obtain credit defective parts must be returned to I.C.E. Inc, at the customer's expense, within 30 days. After 30 days a 15% re-stocking fee will apply to all returns.

ICE distributors are independent, privately owned and operated. In their judgment, they may sell parts and/or accessories other than those manufactured by I.C.E. Inc. We cannot be responsible for the quality, suitability or safety of any non-I.C.E. part or modification (including labor) that is performed by such a distributor.

Innovative Concepts in Entertainment
10123 Main St.
Clarence, NY 14031
Phone #: (716) - 759 - 0360
Fax #: (716) - 759 - 0884
www.icegame.com